

Internal Location Based Services using Wireless Sensor Networks and RFID Technology

M.J.Callaghan, P.Gormley, M.McBride, J.Harkin and TM.McGinnity

Faculty of Engineering, University of Ulster, Derry, Northern Ireland

Summary

Rapid advances in wireless technologies and the near ubiquitous nature of portable mobile devices provide an opportunity to develop and deliver new types of location centric applications and services to users. However the majority of the current location based systems lack sufficient granularity and accuracy. This paper attempts to address some of these issues and presents an internal location tracking system based on the integration of RFID, wireless sensor networks and Wi-Fi that can accurately track users in an environment and subsequently present the user with context aware location specific information. The architecture developed is flexible and could be deployed in a range of application domains including tourism and inventory tracking.

Key words:

Location based services, RFID, wireless sensory networks.

Introduction

Rapid advances in wireless technologies and the near ubiquitous nature of portable mobile devices provide an opportunity to develop and deliver new types of location centric applications and services to users. However the majority of the current location based systems (LBS) lack sufficient granularity and accuracy e.g. GPS [1] and Placelab [2]. This research attempts to address some of these issues and presents an indoor positioning system architecture based on a combination of wireless sensor networks and RFID technology. The approach used integrates RFID readers connected to endpoint nodes of a wireless sensory network to track and locate mobile objects with RFID tags attached. This allows an accurate and localised method of determining location by detecting the presence of a RFID tag attached to an object as it passes in close vicinity to strategically placed and diversely located RFID readers. This solution offers a number of benefits. The wireless sensory network over which the data is transmitted is a low data rate network and uses low powered wireless allowing for the widespread deployment of nodes. The use of passive RFID tags means minimal power requirements on the mobile objects offering a cost-effective way to track multiple objects passing through the network.

In addition the short range of the RFID readers used ensures that the system is able to determine position to a high degree of accuracy. Section two of the paper reviews some of the previous research carried out on location identification and positioning systems. Section 3 describes the design, implementation and testing of the RFID/Wireless sensory network. Section 4 evaluates the overall operation and performance of the architecture and the scope for future research in this area.

2. Current Location Identification Approaches

Existing approaches to location identification can be divided into two main sub categories, external and internal location determination. External positioning systems are usually GPS based (Global positioning systems) or operationally dependant on the augmentation and utilisation of existing infrastructure e.g. location of mobile phone masts. GPS uses satellites and works by calculating the time it takes a signal to travel from a satellite to a receiver on a handheld device. Accuracy to within a few metres is achievable using differential GPS [3]. However this approach can be time consuming and unreliable as the GPS receiver needs to be able to communicate with at least four satellites before location can be found. In addition the receiver must maintain a line-of-site transmission with the satellites. As a direct consequence GPS does not work well in built-up areas such as large cities and is not accessible indoors. An alternative method for determining user location is by using the cellular/mobile telephony GSM system and the known location of base station cells [4,5]. This approach estimates location using a range of different techniques based on signal transmission between the base station cell and the mobile device. This approach is not as accurate as GPS and is dependent on the coverage size of the cell stations used with typical accuracy limited to 200m in urban areas [4]. Examples of the use of this type of approach are becoming more commonplace e.g. I-Mode Streetmap [6] and Vodafone Live Find and Seek service [7].

A number of internal positioning systems are under development. Placelab runs an application on the user's local device to infer current location by using the known longitude and latitude and unique identifier of existing fixed Wi-Fi hotspots, Bluetooth nodes or GSM stations. This observational approach preserves user privacy as the majority of network access points periodically broadcast their presence and monitoring the appropriate frequencies allows these signals to be intercepted and utilised for this purpose. The functionality of Placelab is limited in that it can identify the user's location but then relies on the development of a complementary application to utilise this information effectively. Placelab's accuracy varies widely and is typically within 150 meters using GSM coverage and in the range of 20-50m using Wi-Fi [2].

Active Badge, developed at Olivetti research laboratories used infrared technology for indoor location positioning but encountered two major limitations based on line-of-sight requirements and short-range signal transmission [8]. SpotON uses RFID technology for three dimensional location sensing based on radio signal strength analysis [9]. A range of object location tags were designed and built and located by homogenous sensor nodes without central control. Other approaches have been proposed based on triangulation methods using nodes in a local wireless network; e.g. Wi-Fi or Bluetooth. These methods can produce sufficiently accurate results for indoor positioning but require a high power, high data rate network infrastructure which is not always readily available [10].

The current range of available external positioning solutions are sufficiently accurate to provide basic user services related to the location of facilities and direction finding. As a consequence consumer demand for GPS in cars is increasing, confirming rapid user acceptance and demand for these types of services [1]. The internal tracking of users and devices for location based services requires a higher degree of accuracy which is not currently available using existing approaches.

This research attempts to address some of these issues and presents an accurate indoor positioning system architecture based on wireless sensor networks and RFID technology. The approach used integrates RFID readers connected to endpoint nodes of a wireless sensory network to track, locate and identify the position of people or objects. The architecture proposed allows the subsequent development of a range of applications on this infrastructure for a diverse range of possible uses e.g. tourism or inventory management.

3. System architecture and implementation

The proposed system architecture combines the benefits of wireless sensor networks and RFID technology in the design and implementation of an internal positioning system for tracking the location of objects/people in a building. As a demonstrative example the architecture will be used to provide location/context specific information and content to a user via a PDA. Figure 1 provides a high level overview of the system architecture.

The operation of the system is based on strategically located RFID readers placed around the building identifying passive RFID tags with unique identifiers attached to each PDA. When a PDA passes an endpoint in the wireless sensor network the attached tag is read by the connected RFID reader. The RFID reader communicates the tag ID to the endpoint which then transmits the data through the wireless sensor network back to the gateway. The gateway stores the data corresponding to the location of that particular PDA to a database on the server. A client application on the PDA regularly queries the database which then sends back location specific content to it using the Wi-Fi network.

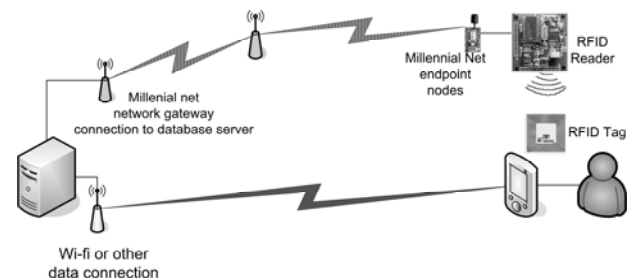

Fig. 1 High-level Network model of overall system

To minimise network deployment costs a means of transporting the data back to a central processing location was required and this was achieved using the low-powered Millennial Net wireless sensory network [11]. This class of wireless networks are self configuring meaning that once deployed, minimum maintenance will be required. Network operation is robust, self healing and fault tolerant with the functionality to re-route data around problem areas to a gateway attached to the host PC. This is achieved using an ad hoc self-organizing approach, combining micro-power sensor interface endpoints and routers with the gateway to form a reliable, scalable star-mesh wireless network [11].

The endpoints used are small with the flexibility and functionality to be attached to a range of analogue/digital sensors and actuators. The radio frequency identification (RFID) system used has two main components, the reader and the tags. The RFID reader is used to perform read/write operations to and from the tags using a fitted antenna. The two most common types of RFID tags are active and passive, differentiated by the need for an on board power source. Active tags are typically used for long range tracking and monitoring of high value items and containers [12]. The onboard power supply increases the range and data storage capabilities of the tags but at the cost of size, price and increased levels of maintenance. Passive tags have no internal power supply and are powered through induction by the reader [13]. Readers periodically transmits a radio signal and if there are any tags in the vicinity the electromagnetic wave emitted induces a voltage on the tag which is then used to transmit the identification signal back to the reader. Passive tags are smaller, relatively inexpensive and easy to manufacture but have limited data storage capabilities and are currently in widespread use e.g. Wal-Mart [14].

The implementation of the architecture required a number of steps. In the first instance a method had to be found to interface the endpoints in the wireless network with the RFID readers. This created a network to read information from the tags and communicate the data across the wireless network back to a central server which then processed the data and returned location specific content to the user. To make the physical hardware connections a number of options were considered. The RFID readers and the Millennial Net endpoints both have serial interfaces for communication, but this port is used by the reader for receiving control commands from the host PC. Another problem arose when considering the integration of the reader with a microcontroller to address the control problem in that the serial port was incompatible with the UART on the Millennial Net endpoint. Further issues arose because the Millennial Net hardware implemented the UART communication handshake in a different manner than the RFID reader i.e. the endpoint UART transmits any serial data in the buffer without waiting for the RTS-CTS handshake. After further investigation it was found that both the RFID readers and the endpoints have digital I/O capabilities and this method of integration was chosen.

In order to ensure that the communication of packets between the RFID reader and endpoint did not result in any data loss it was necessary to develop a simple handshake protocol using the API libraries on both pieces of hardware. The protocol developed is a simplified

version of a serial communication interface and uses four of the digital I/O pins on each device, with each pin designated as either; Transmit Data (Tx), Receive Data (Rx), Request To Send (RTS), and Clear To Send (CTS). When the RFID reader has a packet to send to the endpoint the device sets the RTS pin to logic 'high'. Once the endpoint reads a high on this pin it knows the reader has data to transmit and acknowledges that it is ready to receive the information by setting the CTS pin to high. When the reader receives this acknowledgement it proceeds to transmit one bit of data and then sets the RTS to low to inform the endpoint knows that it has finished transmitting. The endpoint will then set the CTS to low to indicate that it has received the data and the process repeats until all data has been sent (Figure 2).

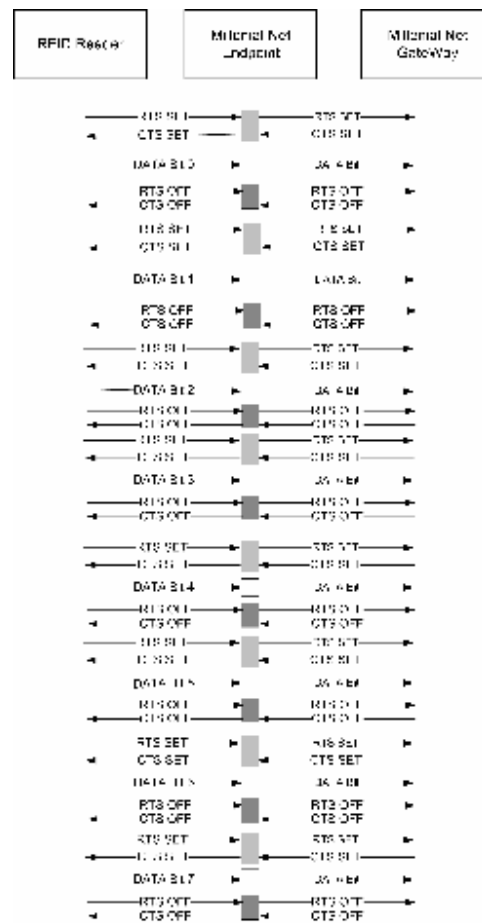

Fig.2 Digital I/O communication protocol

As the endpoints are not physically connected to the gateway there is an inherent time delay between setting a pin high on the RFID reader and then reading this change in pin value on the endpoint. This time delay is dependent

on the sampling rate of the wireless network and also the number of hops a packet has to make before it reaches the gateway.

The Millennial Net system has a maximum sampling rate of 10 Hz; therefore the maximum possible speed of data transmission between the end-point and RFID reader is approximately 1 byte per second. However in practice this is not achievable due to time delays between the information being written to the endpoints digital I/O pins and the update time of the network.

In order for the system to be able to track the position of multiple RFID tags passing through numerous different locations it was necessary to store data specific to each tag in a database i.e. which PDA it is attached to and which user the PDA belongs to. A database was constructed in Microsoft Access containing three tables which is stored on the server (Figure 3). In Fig.3, Table 1 contains a list of users in one column and their unique Tag ID in the other. Table 2 contains a list of RFID reader locations in the first column corresponding to a list of endpoint ID's in the other column. These two tables can only be edited at the server, meaning that tags or locations that are not found in the database will not be displayed on the client application.

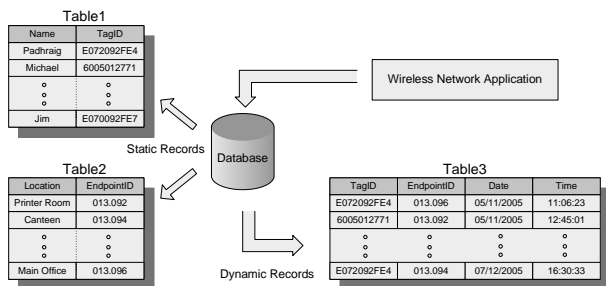

Fig.3 Tables in the Database

The values in the third table are dynamic and are updated with data sent across the wireless sensor network. The sequence of operational events are as follows; a RFID reader detects a tag nearby and transmits the unique Tag ID through the digital I/O to the endpoint. The endpoint transmits the Tag ID (along with its own unique Endpoint ID) back to the gateway application. At this stage a time stamp is added to the data which is then written to fields in Table 3 of the database. Each record contains the Tag ID, the Endpoint ID and a date/time stamp meaning that Table 3 can be queried and cross-referenced with Tables 1 and 2 to return the user of a particular tag, along with the time and date of detection at an endpoint location. The next stage in the process is to present the location specific

content stored in the database back to the user via the PDA over the wireless network. To do this a client side application was developed for the PDA.

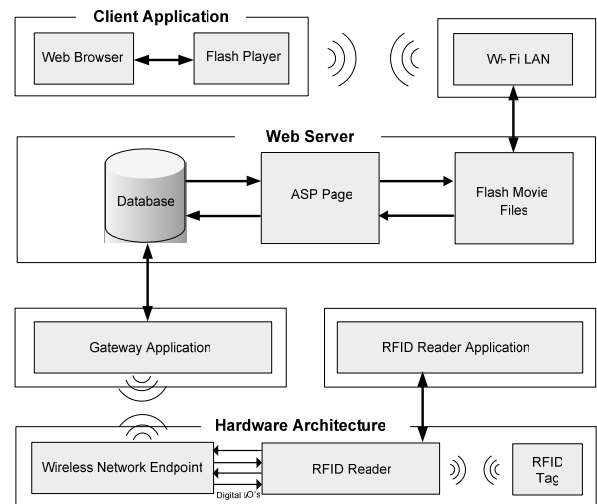

Fig.4 Communication Model

Due to the client application's ubiquitous nature a web browser was the most natural choice for the user interface. In addition Macromedia Flash was chosen as the implementation platform to run in the browser as it allowed the development of more aesthetically pleasing user interfaces. To complete the connection between the Macromedia Flash interface\movie and the database it is necessary to use an intermediate piece of software. This was achieved using Active Server Pages (ASP). In this instance the Macromedia Flash application running in the browser requests location specific information related to a particular tag by passing the ASP page a Query String request. The ASP page then uses C# to connect to the database and query records about a particular tag with the SQL select statements. The ASP page takes the returned query results which are then passed back to the Macromedia Flash interface via another HTTP request/response Query String (Figure 4). The developed system was tested using a network that consisted of three RFID readers attached individually to 3 Millennial Net endpoints. The capacity of the system could be increased to twenty endpoints per gateway if required. The system operation was able to successfully and accurately track five individual users and PDA's across the three reader locations and sends back location specific content over the Wi-Fi networks to the users.

Figure 5 gives a walk-through description of the client application when the PDA passes an RFID reader in the network. The prototype system developed provides a

viable solution to indoor positioning and tracking but suffers from a number of limitations. The RFID reader used in this demonstration has a limited range and while this ensures a very high level of accuracy it also requires a large number of readers placed in the environment to ensure adequate coverage. The use of longer range readers would allow greater coverage with fewer units, but would result in less accuracy and would also add a power requirement to the tags. The interface between the current RFID reader and the Millennium Net endpoint poses further problems and the current solution is inadequate for moderate to heavy traffic patterns due to an inherent delay in transmitting the data across the network..

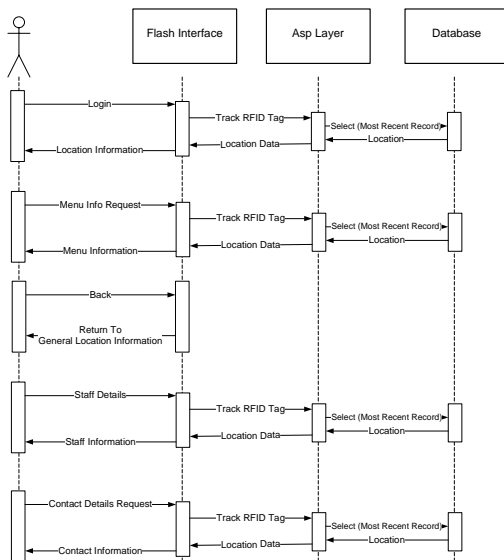

Fig.5 Application Client/Server Operation

4. Conclusion

This work presented an accurate, internal low powered location based architecture with possible applications in the areas of tourism and inventory tracking. The system presented was based on the integration of RFID readers, a wireless sensory network and Wi-Fi and was capable of accurately locating users and sending context specific information based on location back to the user. The range of the RFID readers used in this instance had mixed effects on the performance of the architecture. The initial short range approach exhibited minimum interference from nearby readers and the problem of multiple detections was not an issue. Further investigation will be carried out using different readers with varying

ranges to determine the optimum combination of reader deployment and area coverage. In addition the speed of communication across will need to be improved to enhance the performance of the system. Currently only minimum location aware text based content is passed back to the user. Given the flexibility of the Macromedia Flash development environment this could be greatly improved to include animation, audio and video.

Rapid user acceptance and usage of existing location based services are encouraging the development of more extensive and accurate systems with the focus on improving internal positioning technologies. The accompanying increase in accuracy will further fuel the development of new fine grained applications deployed on this infrastructure.

References

- [1] Hoffmann-Wellenhof, B. H. Lichtenegger, and J. Collins. 1994. GPS: Theory and Practice. 3rd ed. New York: Springer-Verlag.
- [2] LaMarca A., Chawathe Y., Consolvo S., Hightower J., Smith I., Scott J., Sohn T., Howard J., Hughes J., Potter F., Tabert J., Powledge P., Borriello G. and Schilit B. "Place Lab: Pervasive Computing: PERVASIVE 2005, Springer-Verlag GmbH, Munich, Germany, May 8-13, 2005, Vol. 3468, p. 116
- [3] Junglas, I. A., "An Experimental Investigation of Location – Based Services", HICSS '05, p. 85a, Proceedings of the 38th Annual Hawaii International Conference on System Sciences (HICSS'05) - 03-06 Jan. 2005, Track 3, 2005.
- [4] Jana R., Johnson T., Muthukrishnan S. and Vitaletti A., "Location Based Services in a Wireless WAN (CDPD)", MobiDe '01: Proceedings of the 2nd ACM international workshop on Data engineering for wireless and mobile access, 2001, ACM Press, New York, NY, USA, p 74-80
- [5] Mountain, D., Raper, J., "Positioning techniques for location based services characteristics and limitations of proposed solutions", Aslib Proceedings: New Information Perspectives (2001) Vol. 53, no.10, p 404-12, Aslib, UK,
- [6] StreetMap.co.uk, <http://streetmap.co.uk/>, December – 2005
- [7] Vodafone UK, http://vodafone-i.co.uk/live/find_seek.html, Downloaded 08 - December – 2005
- [8] R. Want, "The Active Badge Location System," ACM Trans. Information Systems, Jan. 1992, pp. 91-102.
- [9] Jeffrey Hightower, Chris Vakili, Caetano Borriello, and Roy Want, "Design and Calibration of the SpotON AD-Hoc Location Sensing System", UWCSE 00-02-02, University of

Washington, Department of Computer Science and Engineering, Seattle,

- [10] Nissanka B. Priyantha, Anit Chakraborty, and Hari Balakrishnan. The cricket location-support system. In Proceedings of MOBICOM 2000, pages 32-43, Boston, MA, August 2000. ACM, ACM Press.
- [11] Rhee, S., " Issues in Low Power, Low Data-Rate Wireless Sensor Networks," IEEE Radio and Wireless Conference (RAWCON) 2004, Atlanta, GA, September 20, 2004
- [12] Hähnel D., Burgard W., Fox D., Fishkin K, and Philipose M., "Mapping and Localization with RFID Technology",. Proceedings. ICRA '04. IEEE International Conference on Robotics and Automation, 2004, Page(s):1015 - 1020 Vol.1
- [13] Ho, L., Moh M., Walker Z., Hamada T. & Su C.-F., "A Prototype on RFID and Sensor Networks for Elder Healthcare: Progress Report" SIGCOMM'05 Workshops, August 22–26, 2005, Philadelphia, PA, USA, p70-75, ACM
- [14] Weinstein, R.; "RFID: a technical overview and its application to the enterprise" IT Professional, Volume 7, Issue 3, May-June 2005 , p. 27 – 33



Michael Callaghan is a Lecturer in the School of Computing and Intelligent Systems at the University of Ulster. He holds a Bachelor of Technology in Electronic Engineering and a Masters of Science in Computing and Design. He is a member of Intelligent Systems Engineering Laboratory with the University of Ulster. His current research interests relate to the Remote Experimentation and Hybrid Intelligent Systems.



Padhraig Gormley graduated from the University of Ulster with a MSc in Computing and Intelligent Systems in 2005. He has been a Research Officer in the Intelligent Systems Engineering Laboratory since October 2005. His main areas of interest are wireless sensory networks.



Michael McBride graduated from the University of Ulster with a MSc in Computing and Intelligent Systems in 2005. He is a Research Officer in the Intelligent Systems Engineering Laboratory. His main areas of interest include wireless sensory networks and embedded systems.



Jim Harkin is a Lecturer in the School of Computing and Intelligent Systems at the University of Ulster. He holds a Bachelor of Technology in Electronic Engineering, Masters of Science and PhD from the University of Ulster, and is a member of the IEE. He is a member of Intelligent Systems Engineering Laboratory with the University of Ulster and his current research interests relate to the design and implementation of intelligent reconfigurable embedded systems.



Martin McGinnity is Professor of Intelligent Systems Engineering at the University of Ulster. He holds a first class honours degree in physics, and a doctorate from the University of Durham. He is a Fellow of the IEE, member of the IEEE, and a Chartered Engineer and leads the research activities of the Intelligent Systems Engineering Laboratory. His research interests relate to the creation of intelligent computational systems and the area of intelligent systems in general.