

Performance Improvement using Directional Antennas in Ad Hoc Networks

Hetal Jasani, Kang Yen

Department of Electrical and Computer Engineering
College of Engineering and Computing
Florida International University, MIAMI, FL, USA

Summary

Novel preventive link maintenance scheme based on directional antennas has been proposed to extend the life of the link for multihop infrastructureless networks such as Mobile Ad Hoc Networks (MANET). We use the ability of directional antennas to orientate radio signals into the desired directions. We investigate preventive link maintenance scheme to on-demand routing algorithms. The scheme of creating directional link is proposed to extend the life of link that is about to break. To be more specific, preventive warning is generated to previous node in the path to create directional antenna pattern. Link is considered in danger when received packet power is close to minimum detectable power. We call orientation handoff to the process of changing the pattern of antenna from omnidirectional to the directional. We see the performance improvement at network layer by using the proposed scheme. We do a comparative performance study between omnidirectional and directional antennas for DSR (on-demand routing protocol) using simulation with OPNET. By using directional antennas, substantial gain is achieved in terms of end-to-end delay, aggregate throughput, average data packets dropped, packet delivery ratio, and routing overhead. The proposed scheme is general and can be used with any other on-demand routing algorithms.

Key words:

Directional Antennas, Mobile Ad Hoc Networks, Network Layer, On-Demand Routing Protocols, Dynamic Source Routing, and Physical Layer.

1. Introduction

Typically, in Ad Hoc Networks, omnidirectional antennas have been used to communicate with other nodes for transmission as well as for reception. Omnidirectional antennas may not be efficient due to interference caused by the transmission of packets in all directions (other than target direction) and limited range of communications. Directional antennas may be useful to increase network efficiency by directing the transmitted power in the desired

direction towards target location. Due to the mobile nature of Ad Hoc Network nodes in their applications, it is important to observe the effect of directional antennas on network layer. We propose novel scheme of link life extension by using directional radiation pattern, which helps to avoid or delay route rediscovery operation in routing protocol. Route rediscovery operation is expensive process in terms of network resources and control overhead.

Recently, there has been increasing interest in developing protocols at link layer and network layer for Ad Hoc Networks where nodes are equipped with directional antennas [4, 6, 8, 12, 14, 16]. Previous researchers have shown, directional antennas based communications increase throughput because of better spatial reuse of the spectrum [5, 7, 8, 13, 15]. By exploiting capabilities of directional antennas, we propose a novel link maintenance scheme that yields better throughput, lower end-to-end delay, reduce the number of data packets dropped, increase packet delivery ratio and decrease routing overhead.

In traditional routing algorithms of wired, wireless and mobile networks, a change of path (route) occurs in one of two cases: (i) a link along the path fails; or (ii) a shorter path is found. A link failure is very expensive since: (i) multiple retransmissions/timeouts are required to detect the link failure; (ii) a new path has to be found and used (in on-demand routing) since spare path may not be readily available. In wired networks, route rediscovery is not very expensive since paths don't fail very frequently. Routing protocols in mobile and wireless networks also follow the same model although they have significantly higher frequency of path disconnections. For each path break (in IEEE 802.11 standard), three MAC (Medium Access Control) layer retransmissions (total of four time-outs including the original transmission) are required before a link is considered broken.

A preventive link maintenance scheme proposed here initiates local recovery action early by detecting that a link

is likely to break soon and uses directional antenna pattern to prevent link failure and thus extend the life of the link and reduce the cost of link failure. The scheme maintains connectivity by proactively establishing a “higher quality” link when the quality of a link in use becomes suspect. Note the similarity to on-demand protocols: we replace link failure, with the likelihood of failure as the trigger mechanism for directional antenna orientation instead of sending RERR (Route Error packet) to source node, which initiates costly operation of route rediscovery for new path from source to destination. We study the effectiveness of proposed preventive link maintenance scheme by simulating with OPNET software [1] for DSR routing algorithms. Our scheme can be used for any other kinds of routing algorithm.

We have organized our paper in the following way. Section II overviews ad hoc routing algorithms and DSR (Dynamic Source Routing) in detail. Section III discusses the related work in this area. Section IV discusses the antennas model used in the proposed scheme. Section V explains our preventive link maintenance scheme. We discuss performance evaluation in Section VI, in which we discuss simulation environment and results. At the end, we made some concluding remarks.

2. Ad Hoc Routing Algorithms

For multihop wireless networks, traditional Internet routing protocols are no longer efficient since the network topology is being changed dramatically due to node(s) movement. It presents a great challenge for a routing protocol to keep up with the frequent and unpredictable topology changes. Existing multihop wireless routing protocols can be generally categorized into two classes: table-driven (such as DSDV [19] and WRP [23]) and demand-driven (or Source-initiated such as DSR [18] and AODV [20], ZRP [24], LAR [25]).

Table-driven routing protocols of wireless networks are similar to the routing protocols used in the wired network. They attempt to maintain consistent, up-to-date routing information from each node to every other node, regardless of the need of such routes. They respond to topology changes by propagating updates throughout the network. In contrast, on-demand (reactive) routing protocols attempt to discover a route to a destination only when it is needed or when it senses some activities to forward to the destination. These discovered routes are maintained by a route maintenance procedure until either the destination becomes inaccessible along every path from the source or until the route is no longer desired. Most of the performance studies indicate that on-demand routing protocols perform better than table-driven routing

protocols [21,22]. The major advantage of the on-demand routing comes from the reduction of the routing overhead, as high routing overhead usually has a significant performance impact in low bandwidth wireless networks.

Overview of DSR protocol is presented here briefly since DSR is used to integrate with 802.11 and directional antennas as representative of on-demand routing protocols. DSR is a reactive (on-demand) routing protocol that is based on the well-known concept of source routing [2]. The protocol includes two major operational components: Route Discovery and Route Maintenance, and three types of route control messages, i.e., Route Request (RREQ), Route Reply (RREP), and Route Error (RERR). When a source node in the mobile ad hoc network attempts to send a packet to a destination but it does not have a route to that destination in its route cache, it initiates a route discovery process by broadcasting a route request packet (RREQ). This route request packet contains the source node address, the destination node address, unique sequence number, and an empty route record. Each intermediate node, upon receiving a route request for the first time, will check its own route cache. If it has no route to the destination, the intermediate node will add its own address to the route record and rebroadcast the RREQ. If it has a route to the destination in its route cache, the intermediate node will append the cached route to the route record and initiates a route reply (RREP) back to the source node. The route reply contains the complete route record from the source to the destination. The intermediate node ignores the late arrival of the same route request by examining the sequence number. If the node receiving the route request is the destination node, it will copy the route record contained in the route request and send a route reply back to the source. In most simulation implementations, the destination node will reply to all the route requests received as DSR is capable of caching multiple paths to a certain destination and the replies from the destination most accurately reflect the up-to-date communication topology.

Due to the node movement, the routes discovered may no longer be valid over time. The route maintenance mechanism is accomplished by sending route error packets (RERR). When a link is found broken, a route error packet is sent back from the node that detects the link failure back to the source node. Each node, upon receiving the route error message, removes all the routes that contain the broken link from its cache.

In DSR, each node transmitting the packet is responsible for confirming that the packet has been received by the next hop along the source route. This can be done by either a link layer acknowledgement (as in IEEE 802.11),

or a “passive acknowledgement” (in which the first transmitting node confirms the receipt at the second node by overhearing the second node transmitting the packet to the third node), or a DSR-specific software acknowledgement returned by the next hop. Thus, once a route is entered into the cache, the failure of the route can only be detected when it is actually used to transmit a packet but fails to confirm the receipt by the next hop. It is very critical to find a mechanism, which helps to avoid such link failure. We have proposed such a mechanism in this paper.

3. Related Work

Recently there have been several papers that have looked into the problem of data link layer and routing layer design for Mobile Ad Hoc Networks where nodes are equipped with directional antennas [4, 6, 8]. Most of the work towards the use of directional antennas has concentrated on MAC layer. The directional antenna models used in various papers include switched beam antennas (the antenna is sectored and one of these sectors is used depending on the direction of the communicating node), multi-beam antennas (here more than one beam can be used simultaneously), and adaptive antenna arrays.

Bao, et al. [6] developed slotted scheduling-based MAC protocols for networks, in which nodes are equipped with directional antennas. The directional antenna considered is a multi-beam adaptive array antenna, which is capable of forming multiple beams. Assumption for the protocols was that nodes could engage in several simultaneous transmissions. Authors developed the neighbor-tracking scheme that is then used to schedule transmissions by each node in a distributed way.

Nasipuri, et al. [4] proposed a directional CSMA/CD mechanism that utilizes a switched beam antenna array and assumes that the gain of the directional antenna is equal to the gain of an omnidirectional antenna. The transmitters use omnidirectional antennas to transmit RTS frames and the receiver antennas remain in omnidirectional mode. Assuming the receiver is idle; it receives the RTS and transmits CTS, again using an omnidirectional antenna. The transmitter estimates the angle of arrival (AoA) of the CTS being received and transmits data using the directed antenna beam. Since the transmissions and receptions involving omnidirectional antenna patterns are susceptible to collisions, this mechanism suffers from high probability of packet error. The authors used a switched beam antenna array that could only switch among a limited number of antenna patterns.

Takai, et al. [7] extended Nasipuri’s work [1] by proposing the use of a caching mechanism to store information about angular location of neighboring nodes. This information is obtained from AoA estimation for frames received by each node. Whenever the medium access control layer receives a packet from an upper layer, it would look in the cache to determine whether it has the information about the angular position of the destination node. If the angular position of the destination node is known, the packet is transmitted using the directional antenna after a directional exchange of RTS/CTS control packets. This helps to decrease the dependency on omnidirectional antennas. The scheme still reverts to omnidirectional mode if angular information is not obtained from the cache.

Choudhury, et al. [8] and Takai, et al. [7] have suggested the use of directional virtual carrier sensing (DVCS), in which a Directional Network Allocation Vector (DNAV) is constructed. The DNAV table stores the angle of arrival of RTS packets along with the duration of data transmission in any given direction. Thus, when the medium access control layer receives a packet from an upper layer, along with the angular profile of the destination node with respect to the source node, the DNAV table is consulted to determine whether the angle overlaps with any of the ongoing transmissions. If there are no overlaps, the packet is transmitted; otherwise, packet transmission is deferred in accordance with a back off mechanism.

In other work, Choudhury and Vaidya [26] have done rigorous analysis of using directional antennas and performance evaluation for on-demand routing protocols such as DSR. They used only single switched beam antennas. They have considerable sweeping delay due to the sequential transmission of same packet with different beam of antennas to cover the entire 360-degree. We use multiple directional antennas to solve the problem of sweeping and deafness.

Ramanathan [13] proposed the scheme for considering higher transmission range using beamforming antennas. He discussed the issues more related to MAC layer and didn’t discuss the issues related to the performance of the network layer.

Very little work [11,17] related to the work presented in this paper has been published on preventive maintenance using directional antennas. Preemptive routing [17] proposed keeps track of signal strengths and look forward to route repair procedures before a link breaks. Router Handoff [11] is the strategy of finding another path preemptively before link actually breaks and pass routing information to another suitably situated node after local

recovery. However, both work don't utilize the ability of directional antennas for the routing performance improvement.

Moreover, the assumption of having same gain for both types of antennas in Nasipuri's work [4] did not exploit the full capability of direction antennas, which give higher coverage (gain) and longer communication range. We exploit this capability of directional antenna for extending the life of link. In addition, we use the location information to decide the direction of communication while Nasipuri [1] and Takai [7] used AoA estimation for frames received by each node. In this paper, we focus on preventive link maintenance scheme for improving the performance of reactive routing protocols such as DSR, while Ramanathan [13] discussed proactive routing protocol over ESPAR antennas.

4. Antenna Model

A directional antenna module is implemented in OPNET [1]. There are two separate modes of operations of this model: omnidirectional and directional [8]. In normal operation, the omnidirectional mode is used, while the directional mode is used for both transmission as well as reception after preventive warning has been generated due to decreasing signal strength in received packet. Node can interchange the modes with negligible latency. We use multiple directional antennas (N) to avoid the sweeping operation and sweeping delay [26] that present in the case of single switched beam antenna. Use of multiple directional antennas would also solve the deafness problem [26] since other antenna elements would be available to listen other communication in other directions.

In Omnidirectional mode, a node is capable of receiving signals from all the directions with a gain of G_o . In the Directional mode, a node can point its beam towards a specified direction with gain G_d (with G_d typically greater than G_o). Moreover, the gain is proportional to the number of antenna beams (i.e., inversely proportional to the beam-width). Since more energy can be focused towards a particular direction, this results in an increased coverage range. Though it is not feasible to have a complete non-overlapping pattern practically, we assume the non-overlapping pattern for directional antennas. To model antenna side lobes, we assume that the energy contributed to the side lobes is uniformly distributed in a circular area. For simulation purpose, we also assume that the side lobe gain is fixed and is set to a very small value.

5. Preventive Link Maintenance Algorithm

In this section, we propose a novel directional link maintenance scheme based on signal strength. We name it Preventive Link Maintenance (PLM) scheme since we take preventive action before link actually breaks. We replace weak omnidirectional link with high quality directional link to extend the life. More specifically, the scheme consists of two components: (i) detecting that a link is likely to be broken soon; and (ii) establishing a directional link to it. Determining when link quality is no longer acceptable (which generates a preventive link maintenance warning) is a crucial component of the proposed scheme. The link quality can incorporate several criteria such as signal strength, the age of a link, and rate of collisions. In this paper, we assume the link quality to be a function of the signal strength of received packets. Since most link breaks can be attributed to link failures due to *node motion* in a typical ad hoc scenario, the signal strength offers the most direct estimate of the ability of the nodes to reach each other. We should keep in mind that signal power variations due to fading and similar temporary disturbances do not generate erroneous preventive link maintenance warnings and hence creation of directional link.

If directional link is established successfully before the omnidirectional link breaks, the cost of overhead for detecting a likely broken omnidirectional link (the retransmit/timeout time) is eliminated using preventive link maintenance. In other words, the cost for creating directional link is justified since the route recovery is initiated locally before the current link actually breaks. Eventually, it helps to improve the performance in terms of reduced latency (end-to-end delay), higher throughput, higher packet delivery ratio and reduced routing overhead.

When the signal power of a received packet drops below an *orientation threshold*, the preventive link maintenance warning is generated. The value of this threshold is significant to the effectiveness of the algorithm – if the value is too low, there will not be sufficient time to create directional pattern before the link breaks. However, if the value is too high, the warning is generated too early with negative side effects of unnecessary computing for creating directional link. Likewise, the moving nodes may change direction and the current link never breaks, rendering the preventive action an unnecessary overhead. Generating the preventive link maintenance warning is complicated due to fading that can cause sudden variations in the received signal power.

The decision to create directional link is made by a node based on measured signal strengths of its neighbors with whom it forms part of an active route. We maintain power information at nodes in terms of the *received power*. The decision to create high quality directional link because of weak signal strength is made when one end of the link senses that the *received power* has dropped below an *Orientation Threshold* and preventive link maintenance warning is generated. Operation of switching to the directional link from an omnidirectional link is called an *Orientation Handoff*. We incorporate *Orientation Handoff* into the DSR protocol by making these changes: Each node maintains a *Neighbor Received Power List* containing the received signal strength for last three received packets originating from each neighbor. This list is updated whenever a packet is received. We measure and store three measurements of packet power to check the consistency and take decision accordingly to avoid generating false warnings.

Every node that is part of an active route, checks its predecessor link and next link strengths for each route while receiving the data packet during normal communications (using omnidirectional antennas). If a node detects that *either* the previous or next link strength along an active route is predicted to fall below the *Orientation Threshold*, it initiates *Orientation Handoff*. If orientation with directional antennas cannot achieve strong link creation, no action is taken and the route is allowed to fail and consequently, standard DSR route repair procedure is followed.

Use of time varying directional antenna patterns is envisioned to help in the establishment of directional links in multihop wireless networks that might otherwise not be possible with the use of omnidirectional antennas. We establish the links using directional antennas depending on the condition (signal strength) of the links within network between active nodes. Creation of directional link requires a priori knowledge of the location of the neighbor nodes or transmission/receiving direction. In this paper, we assume that wireless nodes can employ the techniques such as GPS to determine the direction of communications by having position information of nodes and can use that information to orient their antennas.

While establishing the link, the transmitter and receiver may fall into one of the following scenarios. 1) If the transmitter and the receiver are neighbors and the link between them is established by using an omnidirectional antenna, nodes are called *near neighbors*. 2) If two nodes are not near neighbors, they may be *far neighbors*; the link between them is established by using directional antenna. In this scenario, the source and destination node may

establish a directional link between *far neighbors* by orienting their receiver and transmitter antennas towards each other. In this case, link is called an *extended link* and neighboring nodes are called *far neighbor*. The decision to establish an extended link between *far neighbors* for data transmission, instead of relying on multiple hops, depends on a number of factors, such as delay in establishing the link, feasibility of a directed link and the cost of the link in terms of its effect on aggregate throughput in the network.

The establishment of an extended link between *far neighbors* requires communications between the transmitter and receiver nodes through immediate link (when they are near neighbors) to allow appropriate orientation of transmitter and receiver antennas. This signaling information must be exchanged during omnidirectional communications. The neighboring nodes can use an established omnidirectional link to send antenna orientation commands before it gets too late (because of weakening link) for establishment of extended directional link. The establishment of extended links can result in decreasing the end-to-end delay between end nodes (source and destination) since directional link between those intermediate nodes would eliminate (or reduce) the costly operation of route rediscovery. Depending on communication traffic load and relative positions of other nodes, the extended link will have the varying effect of increasing the overall network throughput.

We keep updating the *Neighbor Received Power List* on all the nodes while using directional link. In some mobility pattern, it may be possible to go back and use omni directional antenna when received signal strength is more than orientation thresholds for at least three consecutive received packets.

6. Performance Evaluation

6.1 Simulation Environment

Now, we illustrate simulation scenario that uses the developed antenna models along with OPNET [1] to characterize network performance. The wireless communication channel is modeled by 13 pipeline stages including antenna gains, propagation delay, signal-to-noise ratio, calculation of background noise and interference noise, transmission delay, etc. This powerful simulation environment enables designers to create realistic wireless scenarios. In this work, we have modified the MANET node model to make it to work with four individual antennas. We have used predefined and fixed beams and

created an antenna pointer model. The antenna gain pattern specified in the Antenna Pattern Editor is used to provide the gain values. Model includes four different antennas to cover four different directions (North-East, North-West, South-East, South-West). Antennas maintain this configuration with respect to the earth's meridian even if the node changes its orientation. Modern antennas can achieve it with the aid of magnetic needle that remains collinear to the earth's magnetic field. The antenna patterns have directional gain of 10 dBi with 90-degree beamwidth.

Table 1. Simulation Parameters

Parameters	Value
Area	2500 x 2500 sq. m
Number of Nodes	50
Directional Gain	10 dBi
Orientation Threshold	3 dBi
Packet Size	1024 Bytes
CBR Packet Arrival Interval	1 ms to 10 ms
Simulation Time	10 minutes
Number of simultaneous connections	5 with a starting time lag of 10 seconds
Mobility Model	Random way point mobility model

We use the network of 50 nodes placed randomly over area of 2500 x 2500 sq. meter. We have 5 random sources of CBR (constant bit rate) each of which generates 1024 bytes data packets to a randomly chosen destination at a rate of 2 to 50 packets per second. All five sources start data transmission with different times. All connections/communications end when simulation ends. For realizing realistic transmission range, the Hata Okumara path loss model [9, 10] is adopted. We use random waypoint mobility model to simulate different patterns of mobility (speed of nodes and pause time). The 802.11 standard protocol is used as MAC layer protocol for simulation. Simulations are run for 600 seconds and all results are averaged over 5 different seeds. We compare our results with original DSR over omnidirectional antennas. Table 1 shows the set of parameters used for our simulations.

We also modified the MANET node model to implement our scheme and to provide all necessary interfaces with the antenna models. The designed model is shown in Figure 1.

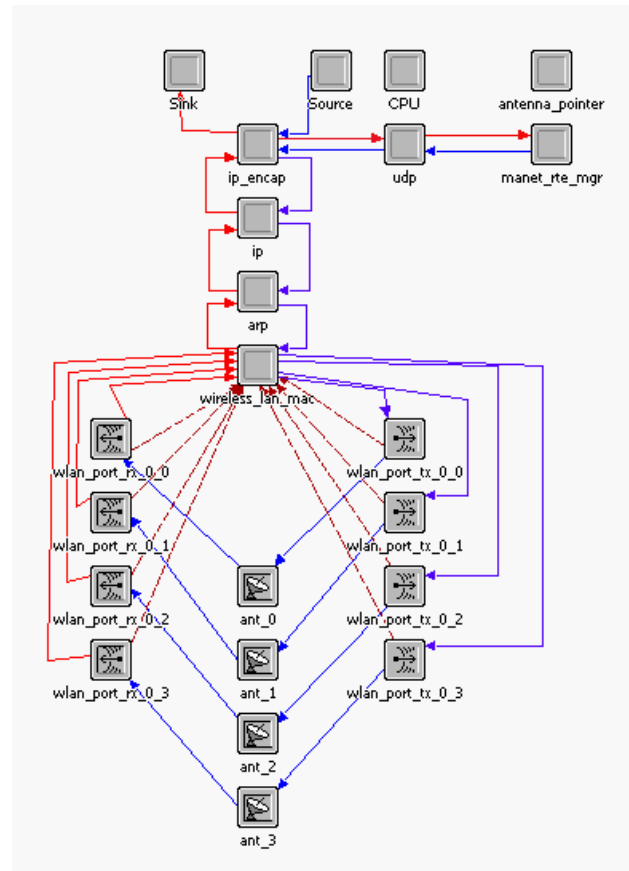

Fig.1 OPNET Node Model

6.2 Simulation Results And Discussions

In this subsection, we analyze the simulation results in terms of aggregate throughput, end-to-end delay (latency), number of packets dropped, packet delivery ratio, and routing overhead.

Aggregate Throughput is the total number of bits transmitted from one node to other nodes in the network per unit of time. It is the total traffic sent and received in bits per second for entire network. We collected this statistic in our simulation scenario and compared with original DSR (with omnidirectional antenna nodes). Our PLM scheme performs better in different scenarios since preventive link maintenance scheme allows link to live longer than omnidirectional case. An establishment of directional link postpones the route rediscovery process and also reduces frequent disconnection. Figure 2 shows that aggregate throughput is higher in our scheme using directional antenna. Aggregate throughput (performance) of entire network for our scheme is about 75% higher than original DSR for higher packet/data rate.

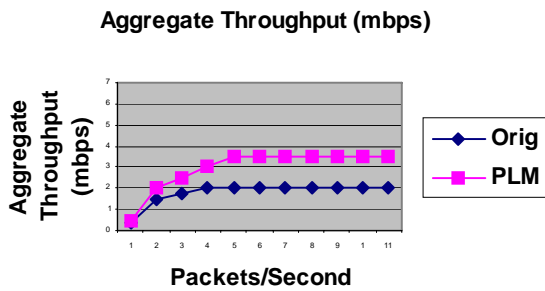

Fig. 2 Aggregate Throughput

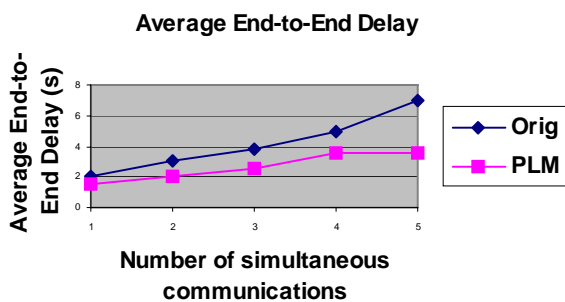

Fig. 3 Average end-to-end delay (latency)

End-to-end delay (latency) of packets for the entire network is the time elapsed between the creation of the packet at its source and its destruction at its destination. It is almost half in case of our scheme when we have five flows communicating simultaneously in compare to smaller number of simultaneous flows. In other words, the average end-to-end delay per packet increases much more sharply for original DSR algorithm than our scheme as shown in Figure 3. It can be concluded that routing performance improves when we have many simultaneous connections. It is also because of the number of directional antennas (four) we use in our simulation.

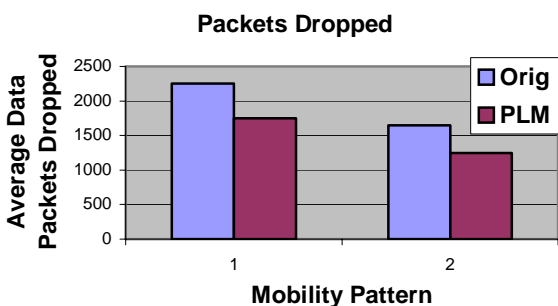

Fig. 4 Average Data Packets Dropped

When route is not found to the destination or the next hop reachability confirmation is not received (ACK not received), the node drops the packets queued for the destination after maximum number of attempted transmissions. This statistic represents the total number of application packets discarded by all nodes in the network. Average data packets dropped are about 20% less in case of our PLM scheme than for original DSR. We have simulated two different types of mobility pattern by choosing the different pause time (0 second pause time/continuous mobility and 20 seconds pause time) in random waypoint mobility model in OPNET as shown in Figure 4.

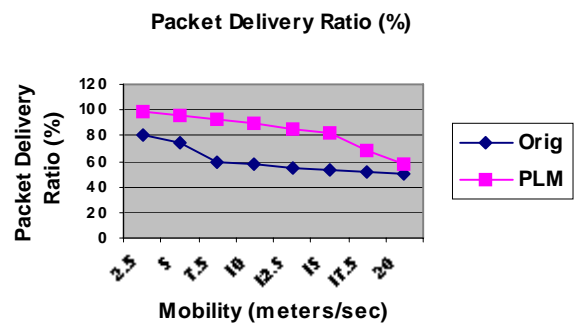

Fig. 5 Packet Delivery Ratio (%)

Packet delivery ratio is the ratio of the packets received to packets generated. Figure 5 shows this statistics. Packet deliver ratio is about 50% higher for PLM scheme than original DSR for mobility of 10-meters/second. This is also because of PLM scheme protects the link failure by creating directional link preventively. Packet delivery ratio drops down drastically for our scheme for higher mobility (20 meters/second), as we do not encourage using our scheme for higher mobility scenario. Still performance is better than original DSR with omnidirectional antennas.

Routing overhead per received packet is the ratio of the total number of routing control packets (including RREQ, RREP and RERR) generated/forwarded to the data packets received correctly at the destination. Figure 6 shows that routing overhead is about 40% to 60% less than original DSR. For high mobility scenario, original DSR produce larger routing overhead where as our scheme has lower routing overhead. Routing overhead increases as speed of mobile node increases, but the increment is slight. In summary, our result is consistent with what is expected in different scenarios.

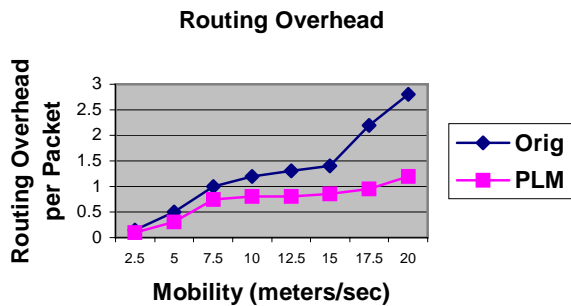

Figure 6. Routing Overhead per Packet

7. Conclusions

A directional antenna module is implemented in OPNET simulator with two separate modes of operations: omnidirectional and directional. The antenna module has been incorporated in wireless node model and simulations are performed to characterize the performance improvement of DSR Ad Hoc routing protocol. The simulation model is developed to evaluate performance improvement when we use directional antennas to extend the life of link, which is about to break. Link breakage happens due to the node movement and subsequent reducing signal strength of receiving packets. A novel preventive link maintenance scheme using directional antennas is proposed to characterize the performance gain. It is achieved by orienting neighboring nodes antennas towards each other by using the position/location information of nodes. It helps ad hoc source nodes to avoid or postpone costly operation of route rediscovery in on demand routing protocols. We compare the simulation results of our Preventive Link Maintenance (PLM) scheme with omnidirectional scheme (original DSR algorithm) by collecting the statistics of aggregate throughput, end-to-end delay, number of data packets dropped, packet delivery ratio, and routing overhead. Use of directional antennas has been found encouraging for on demand routing protocols of MANET using our proposed preventive link maintenance scheme.

References

- [1] Online Documentation, "OPNET Modeler", <http://www.opnet.com/>, Date visited: February 2006
- [2] D.B. Johnson, D.A. Maltz, Y.-C. Hu and J.G. Jetcheva, "The dynamic source routing protocol for mobile ad hoc networks," *IETF Internet draft (November 2001) draft-ietf-manet-dsr-06.txt*
- [3] H. Dajing, J. Shengming and R. Jianqiang, "A link availability prediction model for wireless ad hoc networks," *Proc. of the International Workshop on*

- Wireless Networks and Mobile Computing*, Taipei, Taiwan, April 2000.
- [4] A. Nasipuri, S. Ye, J. You and R. Hiromoto, "A MAC protocol for mobile ad hoc networks using directional antennas," *Proc. of the IEEE Wireless Communications and Networking Conference*, Chicago, Illinois, Vol. 3, September 23-28, 2000, pp. 1214-1219.
 - [5] Z. Huang and C. Shen, "A comparison study of omnidirectional and directional MAC protocols for ad hoc networks," *In Proc. of IEEE Globecom'02*, 2002.
 - [6] L. Bao, and J.J. Garcia-Luna-Aceves, "Transmission scheduling in ad hoc networks with directional antennas," *In ACM/SIGMOBILE MobiCom 2002*, 23-28 Sept. 2002.
 - [7] M. Takai, J. Martin, R. Bagrodia and A. Ren, "Directional virtual carrier sensing for directional antennas in mobile ad hoc networks," *Proc. of the ACM MobiHoc'02*, Lausanne, Switzerland, June 9-11, 2002, pp. 183-193.
 - [8] R. Choudhury, X. Yang, R. Ramanathan and N. H. Vaidya, "Using directional antennas for medium access control in ad hoc networks," *Proc. of the MOBICOM*, Atlanta, Georgia, September 23-28, 2002, pp. 59-70.
 - [9] Okumura et al., "Field strength and its variability in VHF and UHF band-mobile radio service," *Review of the Electrical Communications Laboratory*, Vol. 16, No. 9-10, September-October 1968.
 - [10] Hata, "Empirical formula for propagation loss in land mobile radio services," *IEEE Transactions on Vehicular Technology*, Vol. 29, No. 3, Aug 1980.
 - [11] Abhilash P., Srinath Perur and Sridhar Iyer, "Router Handoff: An Approach for Preemptive Route Repair in Mobile Ad Hoc Networks," *Proc. of High Performance Computing*, 2002.
 - [12] Z. Huang, C. Shen, C. Srisathapornphat, C. Jaikao, "A busy-tone based directional MAC protocol for ad hoc networks," *Proc. IEEE MILCOM*, pp. 1233 - 1238, Oct'02
 - [13] R. Ramanathan, "On the performance of ad hoc networks with beamforming antennas," *Proc. of the ACM MobiHoc*, Long Beach, California, October 4-5, 2001, pp. 95-105.
 - [14] S. Roy, D. Saha, S. Bandyopadhyay, T. Ueda, and S. Tanaka, "A network aware MAC and routing protocol for effective load balancing in ad hoc wireless networks with directional antenna," *In ACM Mobihoc'03*, June 2003.
 - [15] S. Horisawa S. Bandyopadhyay, K. Hausike and S. Tawara, "An adaptive MAC and directional routing protocol for ad hoc wireless networks using ESPAR antenna," *In ACM/SIGMOBILE MobiHoc'01*, Oct 2001.
 - [16] M. Sanchez, T. Giles and J. Zander, "CSMA/CA with beam forming antennas in multi-hop packet radio," *Proc. of the Swedish Workshop on Wireless Ad Hoc Networks*, March 5-6, 2001.
 - [17] T. Goff, N.B. Abu Ghazaleh, D. Phatak and R. Kahvecioglu, "Preemptive Routing in Ad Hoc Networks," *In Proc. of ACM SIGMOBILE*, Rome, pp.43-52, 2001
 - [18] D. Johnson, D. Maltz, "Dynamic source routing in ad hoc wireless networks," edited by T. Imielinski and H. Korth, Kluwer Academic Publisher, pp. 153-181, 1996.
 - [19] C. Perkins, B. Bhagwat, "Highly dynamic Destination Sequence Distance-Vector (DSDV) routing for mobile computers," *in ACM SIGCOMM Symposium on Communication, Architectures and Protocols*, 1994.

- [20] C. Perkins, E. Royer, *Ad-hoc On-demand Distance Vector (AODV) Routing (Internet-Drift)*, Aug.1998.
- [21] J. Broch, D. Maltz, D. Johnson, Y. Hu, and J. Jetcheva, "A performance comparison of multi-hop wireless ad hoc network routing protocols," *Proc. Mobile Computing and Networking (MobiCom)*, pp. 85-97, 1998.
- [22] S. R. Das, R. Castaneda, J. Yan, "Comparative performance evaluation of routing protocols for mobile ad hoc networks," *7th International Conference on Computer Communication and Networks (IC3N'98)* pp. 153-161.
- [23] S. Murthy, J.J. Garcia-Luna-Aceves, "An efficient routing protocol for wireless networks," *ACM Mobile Networks and Applications Journal*, Special issue on Routing in Mobile Communication Networks, 1996.
- [24] Z. J. Haas, "A routing protocol for the reconfigurable wireless network" *In 1997 IEEE 6th International Conference on Universal Person Communications Record. Bridging the Way to the 21st Century, ICUPC '97*, vol2, pp 562-566, October 1997.
- [25] Y.-B. Ko and N. H. Vaidya, "Location-Aided Routing(LAR) in mobile ad hoc networks," *In Proceedings of the Fourth MobiCom'98*, pp. 66-75, October 1998.
- [26] R. Choudhury, N. H. Vaidya, "Performance of Ad Hoc Routing using Directional Antennas," *Journal of Ad Hoc Networks - Elsevier Publishers*, November, 2004.