

Enhanced ERICA Congestion Control Scheme for ATM Networks

M.Sreenivasulu[†], Dr. E.V. Prasad^{††}, Dr. G.S.S. Raju^{†††}

[†]Department of CSE, K.S.R.M. College of Engineering, Kadapa, A.P. India.

^{††}Director, Institute of Science & Technology, J.N.T.University, Kakinada, A.P., India

^{†††}Department of Mathematics, J.N.T.University College of Engineering, Pulivendula, Kadapa Dist. A.P., India

SUMMARY:

Rate based Congestion control schemes promises effective traffic management for the ABR service class suitable to data communications in ATM networks. A rate based scheme uses feedback information from the network to specify the maximum rate at which each source can transmit cells in to the network on every VC. In this paper, we considered an efficient rate based congestion scheme, Explicit Rate Indication Congestion Avoidance (ERICA) for ATM networks. An enhancement to ERICA scheme is proposed. The simulation results shows that enhanced ERICA scheme gives better results than original ERICA scheme.

Keywords: Asynchronous Transfer Mode networks, Congestion, Explicit Rate Indication Congestion Avoidance, NIST ATM Simulator.

1. Introduction

Broadband Integrated Services Digital Network (B-ISDN) with Asynchronous Transfer Mode (ATM) technology [2, 10] will offer multimedia communication, video on demand, live television, and high speed data transport and many other services. Asynchronous Transfer Mode technique is designed to provide fast packet (cell) switching over various types and speeds of media at variable rates from 64 Kbps to 2 Gbps and beyond. ATM networks provides good bandwidth, flexibility and can be used efficiently from desktop computers to LANs and WANs. Unlike other packet switching networks, ATM networks support both fixed and variable bandwidth services. One of the services provided by ATM networks is the Available Bit Rate (ABR) which was proposed for data applications to utilize the left-over bandwidth from other ATM traffic types.

Congestion control mechanisms [1,3,6] are essential for the support of ABR service to provide efficient and fair bandwidth allocation among connections with vague Quality of Service (QoS) requirements. The congestion control is not only essential for regulating the traffic to prevent congestion, but also necessary to provide efficient and fair bandwidth allocation.

Rate based congestion control [2,5,7,9] promises effective traffic management for ABR service class suitable for data communication in ATM networks. In the rate based congestion control mechanism, cell emission rate of each source end system is regulated according to congestion information returned by the network.

In this paper, we considered ERICA congestion control mechanism for ATM networks and enhancement to ERICA is presented. These schemes are implemented using NIST ATM simulator and results were analyzed and compared. This paper is organized as follows. Section 2 gives overview of ABR control mechanism. Overview of ERICA congestion control mechanism is presented in section 3. Enhancement to ERICA scheme is proposed in section 4. Simulation environments and result analysis is presented in section 5. Finally the conclusion of paper is presented in section 6.

2. ABR Control Mechanism

ATM networks offer five classes of service: Constant bit rate (CBR), real-time variable bit rate (rt-VBR), non-real time variable bit rate (nrt-VBR), available bit rate (ABR), and unspecified bit rate (UBR). Of these, ABR and UBR are designed for data traffic, which have a bursty unpredictable behavior.

UBR service is simple in the sense that users negotiate only their peak cell rates (PCR) when setting up the connection. Then, they can send burst of frames as desired at any time at the peak rate. If too many sources send traffic at the same time, the total traffic at a switch may exceed the output capacity causing delays, buffer overflows, and loss. The network tries to minimize the delay and loss but makes no guarantees.

The ABR service provides better service for data traffic by periodically advising sources about the rate at which they should be transmitting. The switches monitor their load and compute the available bandwidth and divide it fairly among active flows. The feedback from the switches to the sources is sent Resource Management

(RM) cells which are sent periodically by the sources and turned around by the destinations. (See figure 1).

The RM cells are sent by sources after every 31 data cells. The RM cells contain the source's current cell rate (CCR) and minimum cell rate (MCR). The RM cells also have several fields that can be used by the switches to provide feedback to the sources. These fields are : Explicit Rate (ER), Congestion Indication (CI) flag, No Increase (NI) flag. The ER field indicates the rate that the network can support at the particular instant in time. When starting at the source, the ER field is set to Peak Cell Rate (PCR). Also, CI and NI flags are cleared. On the path, each switch reduces the ER field to the maximum rate it can support. In certain cases, it can also set the CI and NI flags. The sources monitor the returning RM cells and adjust their transmission rates as instructed by the ER, CI, and NI fields.

The RM cells flowing from the source to the destination are called Forward RM cells (FRMs) while those returning from the destination to the source are called backward RM cells (BRMs).

If a switch or destination becomes extremely congested, it may not want to wait for the next RM cell. They are allowed to generate a limited number of RM cells and send them immediately towards the source. Such RM cells are called "Out-of rate (OOR)" RM cells. The source generated RM cells are "in rate" RM cells because the bandwidth used by them is counted in the rate allocated to the source. Thus, if a source is allocated 32 cells per second, it can send 31 data cells and one RM cell per second (assuming NRM of 32). The out-of rate and in-rate RM cells are distinguished by a BN (Backward Notification) Flag in the RM cells.

When a source receives a BRM, it computes its allowed cell rate (ACR) using current ACR, CI, NI, BN flags, and the ER field of the RM cell.

3. The ERICA Algorithm

The ERICA algorithm [4] is concerned with the fair and efficient allocation of the available bandwidth to all contending sources. Like any dynamic resource algorithm, it requires monitoring the available capacity and the current demand on the resources. Here, the key "resource" is the available bandwidth at a queuing point (input or output port). In most switches, output buffering is used, which means that most of the queuing happens at the output ports. This, ERICA algorithm is applied to each output port (or link).

3.1 The Basic Algorithm

The switch periodically monitors the load on each link and determines a load factor, z , the available capacity, and the number of currently active VCs (N).

The load factor is calculated as the ratio of the measured input rate at the port to the target capacity of the output link.

$$z \leftarrow \frac{ABR\ Input\ Rate}{ABR\ Capacity}$$

Where,

ABR capacity \leftarrow Target Utilization (U) \times Link Bandwidth

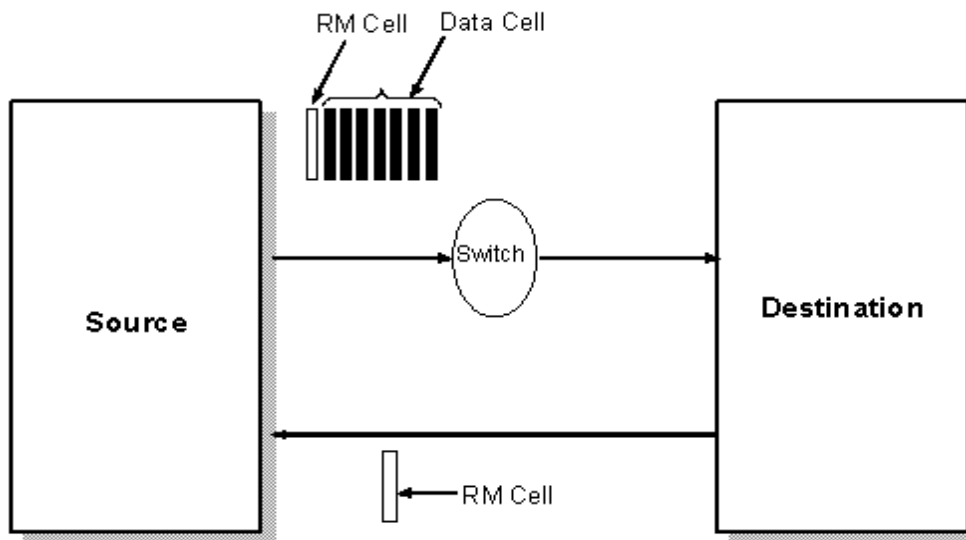

Fig.1: RM Cell path

The Input Rate is measured over an interval called the switch averaging interval. The above steps are executed at the end of the switch averaging interval.

Target Utilization (U) is a parameter which is set to a fraction (close to, but less than 100 %) of the available capacity. Typical values of target utilization are 0.9 and 0.95.

The load factor, z , is an indicator of the congestion level of the link. High overload values are undesirable because excessive congestion; so are low overload values which indicate link underutilization. The optimal operating point is at an overload value equal to one. The goal of the switch is to maintain the network at unit overload.

The fair share of each VC, Fair Share, is also computed as follows:

$$\text{FairShare} \leftarrow \frac{\text{ABR Capacity}}{\text{Number of Active sources}}$$

The switch allows each source sending at a rate below the FairShare to rise to FairShare every time it sends a feedback to the source. If the source does not use all of its FairShare, then the switch fairly allocates the remaining capacity to the sources which can use it. For this purpose, the switch calculates the quantity:

$$\text{VCShare} \leftarrow \frac{\text{CCR}}{z}$$

If all VCs changed their rate to their VCShare values then, in the next cycle, the switch would experience unit overload (z equals one).

Hence VCShare aims at bringing the system to an efficient operating point, which may not necessarily be fair, and FairShare allocation aims at ensuring fairness, possibly leading to overload (inefficient operation). A combination of these two quantities is used to rapidly reach optimal operations as follows:

$$\text{ER Calculated} \leftarrow \text{Max}(\text{FairShare}, \text{VCShare})$$

Source are allowed to send at a rate of at least FairShare within the first round-trip. This ensures minimum fairness between sources. If the VCShare value is greater than the FairShare value, the source is allowed to send at VCShare, so that the link is not underutilized. This step also allows an unconstrained source to proceed towards its max-min rate. The previous step is one of the key innovations of the ERICA scheme because it improves fairness at every step, even under overload conditions.

The calculated ER value cannot be greater than the ABR capacity which has been measured earlier. Hence, we have:

$$\text{ER Calculated} \leftarrow \text{Min}(\text{ER Calculated}, \text{ABR capacity})$$

Since every output port is queuing point through which a VC passes, every source ought to send at no more than the ER calculated at its bottleneck queuing point. To ensure that the bottleneck ER reaches the source, each switch computes the minimum of the ER it has calculated as above and the ER value in the RM cell. This value is inserted in the ER field of the RM cell.

$$\text{ER in RM cell} \leftarrow \text{Min}(\text{ER in RM cell}, \text{ER Calculated})$$

4. Enhancement to Erica Scheme

Most congestion control schemes provide the network administrator with a number of parameters that can be set to adapt the behavior of the schemes to their needs. A good scheme must provide a small number of parameters that offer the desired level of control.

ERICA provides a few parameters which are easy to set because the tradeoffs between their values are well understood.

The Target Utilization determines the link utilization during steady state conditions. If the Input rate is greater than Target Utilization \times Link Capacity, then the switch asks source to decrease their rates to bring the total input rate to the desired fraction.

In ERICA, the target utilization is set to 95%, the remaining 5% used for draining the queue when the input rate is more than the capacity. Thus, the main difference between a system with 95% target utilization and another with 85% target utilization is that in the latter case, the queues due to overload are drained out quickly. Lower target utilization leads to faster response to overloads.

Excessively high values of Target Utilization are undesirable because they lead to long queues and packet loss, while low Target Utilization values lead to link underutilization.

The main problem with lower target utilization is under steady state (when there is no overload), a larger fraction of the capacity is left unused. Thus there is a tradeoff between steady state and transient operation.

We can improve the scheme by varying the target rate dynamically. During steady state, we can set target rate to 100% of link utilization, while it is lower during transient overloads.

In other words,

$$\text{Target rate} = \text{fn}(\text{queue length}, \text{link rate})$$

The “fn” above has to be decreasing the function of queue length.

The pseudo code for setting target rate :

If queue length > Very Congested Queue Threshold

$$\text{Target utilization} = 0.70$$

```

Else
  If queue length > High threshold
    Target utilization = 0.80
  Else
    If queue length < low threshold
      Target utilization = 1.0
  Target rate = Target utilization * link capacity
    
```

5. SIMULATION ENVIRONMENT AND RESULTS

5.1 Simulation Environment

The ERICA scheme was implemented on NIST ATM Simulator [8]. We simulated our congestion control algorithm for a network configuration shown in fig 2.

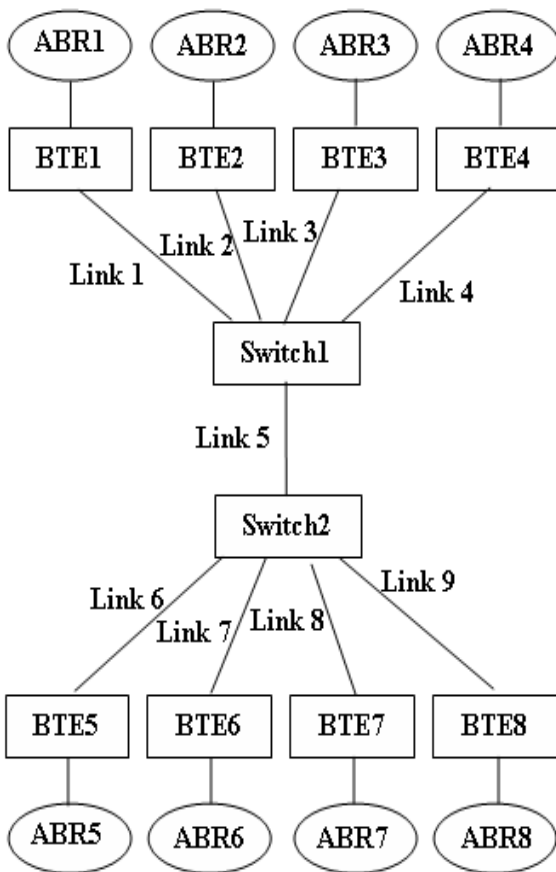

Fig.2 A Sample Network Configuration

There are two switches, four source end systems (Broadband Terminal Equipment BTE1 to BTE4), four destination systems (BTE5 to BTE8), links (link1 to link9) and ABR applications (ABR1 to ABR8).The ABR applications are attached to source and destination

terminals for sending and receiving data. There are four virtual channels in the network. The first Virtual Channel (VC1) is passing through BTE 1,Switch1, Switch2 and BTE5. The second Virtual Channel (VC2) is passing through BTE2, Switch1,Switch2, and BTE 6. The third Virtual Channel (VC3) is passing through BTE3, Switch1, Switch2, and BTE7. The fourth Virtual Channel (VC4) is passing through BTE4, Switch1, Switch2, and BTE 8.

The network parameters are as follows: Link speed = 155 Mbps, Source end terminals (BTEs): Initial Cell Rate =7.49 Mbps , Minimum Cell Rate = 1.49 Mbps, Peak Cell Rate =149.76 Mbps, Switch parameters: Low threshold (cells)= 600, High threshold (cells)= 800 , Very Congested Queue Threshold (DQT) = 900. A switch is said to be congested when queue length of switch larger than predefined threshold.

5.2 Results Analysis

Initially, we simulated ERICA algorithm and measured ACR for source BTEs, percentage of cell drop at switch1 and link utilization of switch2 output links. The results are presented in the form of three graphs for ERICA and enhanced ERICA schemes.

1. Graph of Allowed Cell Rate in Mbps over time for each source.
2. Graph of % cell drop over time at the switch1.
3. Graph of link rate of swith2 output links.

The graphs for ACR Vs. Time for source BTEs , the percentage of Cell Drop Vs. Time at Switch1, Link Utilization Vs. Time of Switch2 output links are shown in fig.3 to 5 respectively.

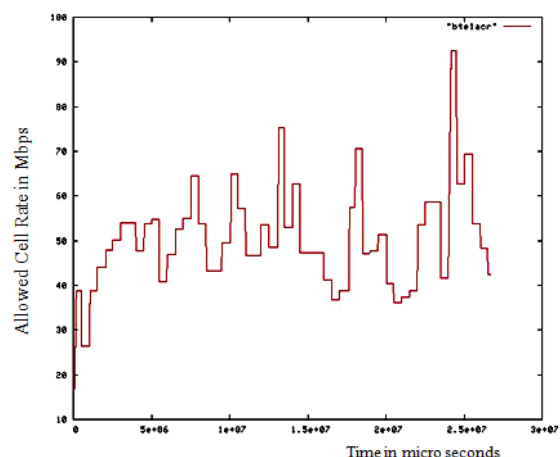

Fig.3(a):BTE1 ACR Vs Time

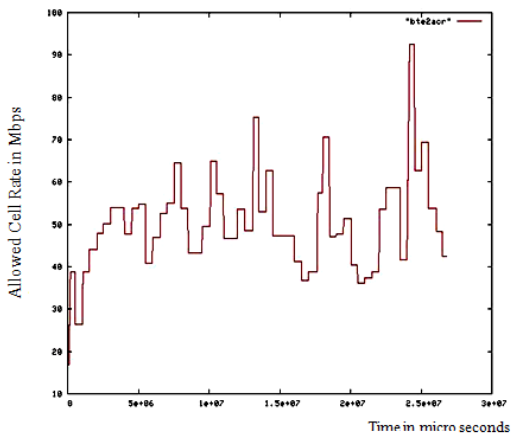

Fig.3(b):BTE2 ACR Vs Time

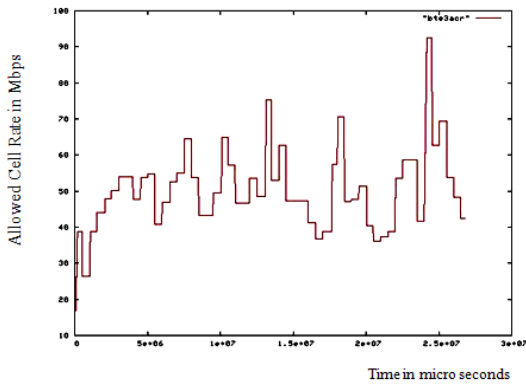

Fig.3(c):BTE3 ACR Vs Time

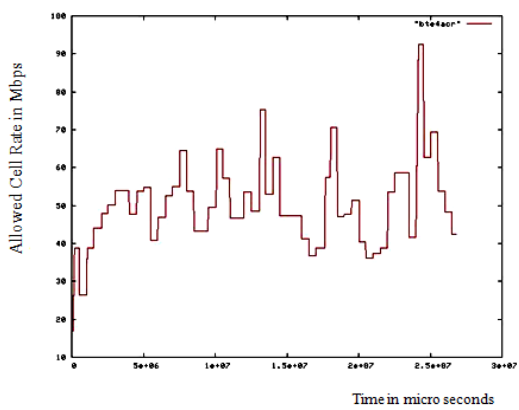

Fig.3(d):BTE4 ACR Vs Time

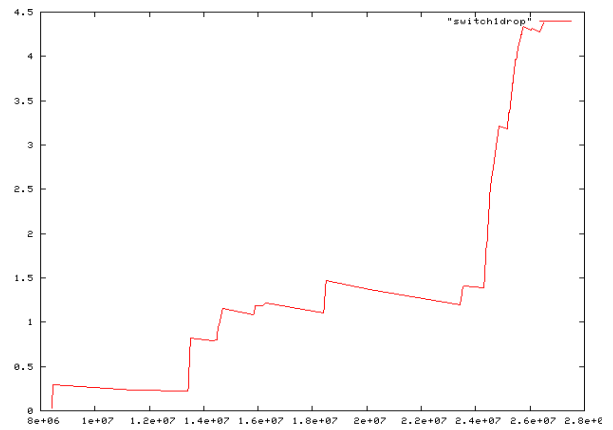

Fig.4: Percentage of Cell drop Vs Time at Switch1

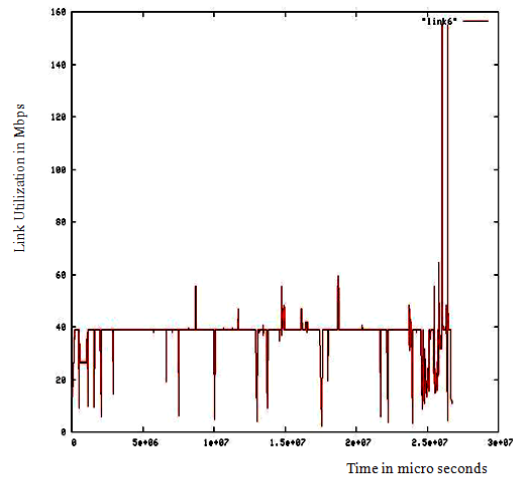

Fig.5(a).Link6 Utilization Vs Time

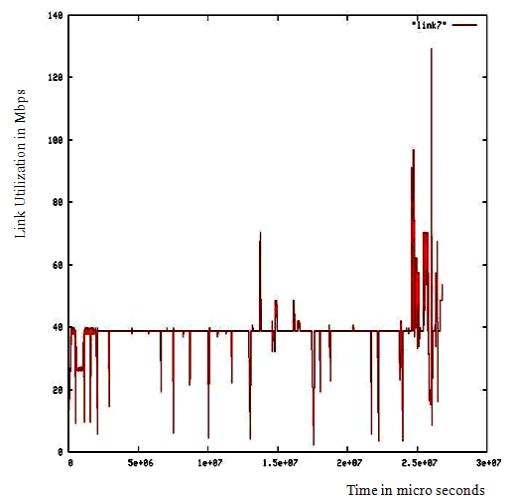

Fig.5(b).Link7 Utilization Vs Time

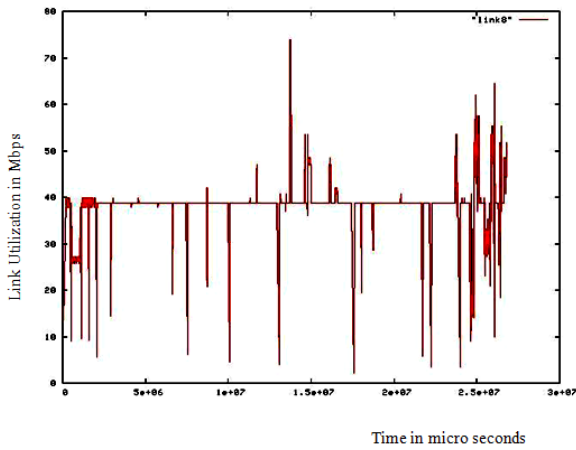

Fig.5(c).Link8 Utilization Vs Time

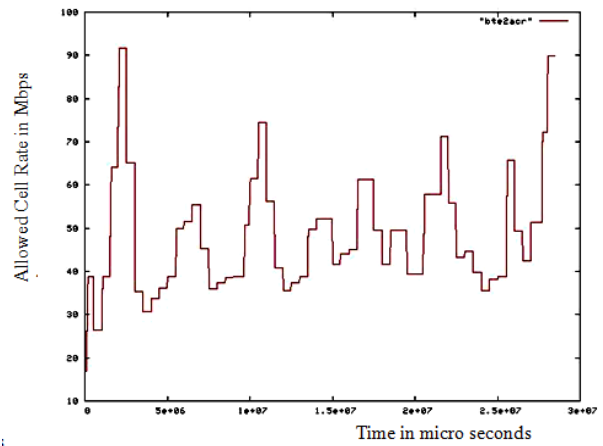

Fig. 6 (b).BTE2 ACR Vs Time

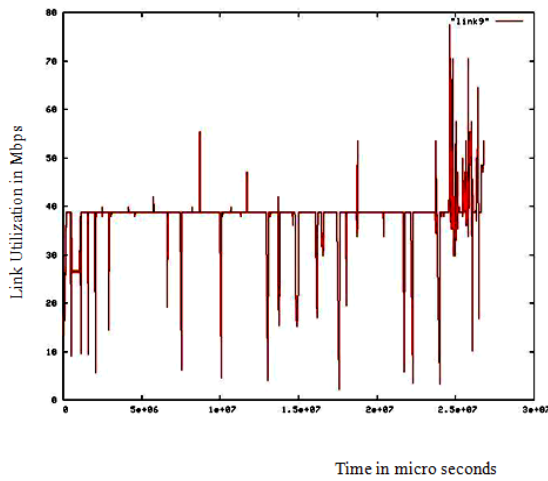

Fig.5(d).Link9 Utilization Vs Time

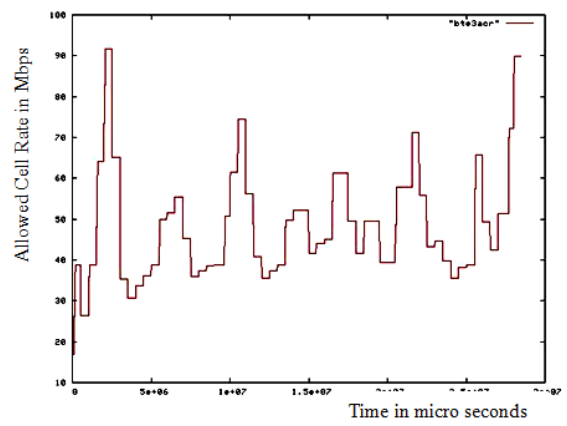

Fig.6(c).BTE3 ACR Vs Time

From the above graphs we can observe that few percentage of cell drop at switch 1 have taken place but fair link utilization for output links of switch 2 are achieved.

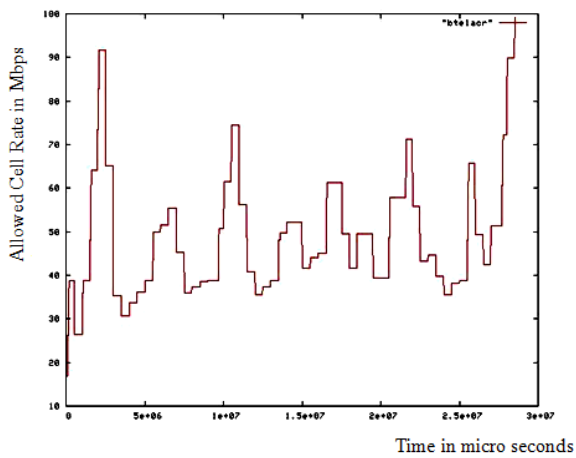

Fig. 6(a).BTE1 ACR Vs Time

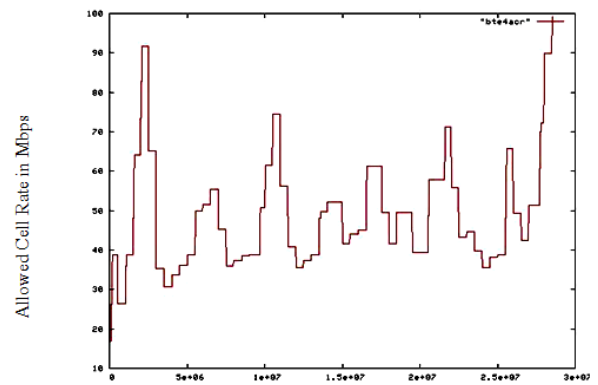

Fig. 6(d).BTE4 ACR Vs Time

Later, we simulated enhanced ERICA scheme and also plotted graphs for ACR Vs Time for source BTEs, % of cell drop at Switch1, and link utilization of output links of switch2, which are shown in figures 6, 7, and 8.

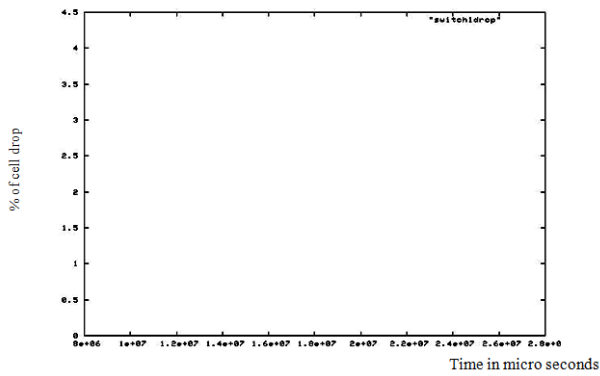

Fig.7 Percentage of Cell Drop Vs Time at Switch 1

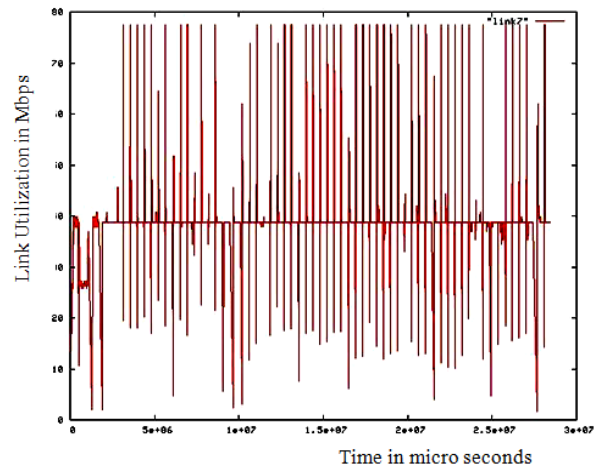

Fig.8(c).Link8 Utilization Vs Time

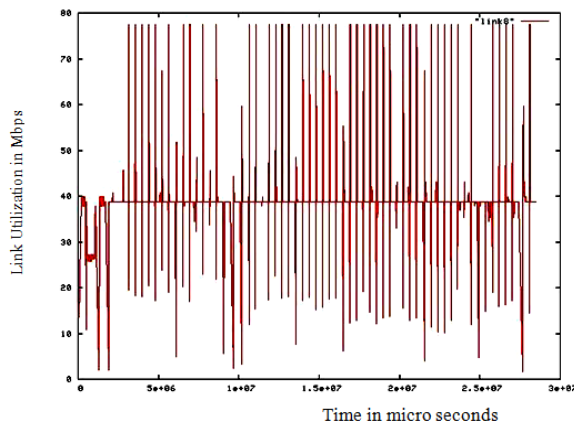

Fig.8(a).Link6 Utilization Vs Time

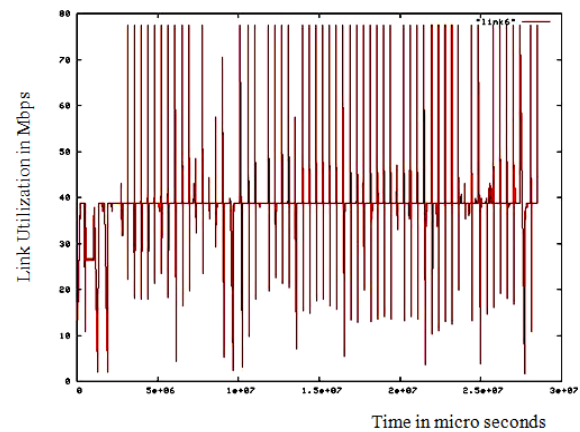

Fig.8(d).Link9 Utilization Vs Time

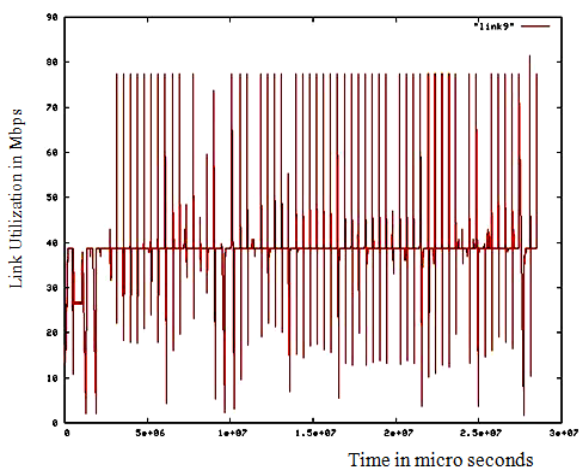

Fig.8(b).Link7 Utilization Vs Time

5.3 Observation on the Results

From the simulation results, we can make the following observations about the performance of enhanced ERICA scheme.

- Allowed Cell Rate (ACR) of source terminals (BTEs) and link utilization of output links of Switch2 are better than original ERICA scheme.
- In the case of original ERICA scheme, we can observe that few percentage of cell drops at Switch1 have been taken place. There is zero percentage of cell drop at Swich1 using enhanced ERICA scheme.
- From these observations, we can state that Enhanced ERICA scheme gives better results than original scheme.

6. Conclusion

ERICA rate based congestion control scheme developed for ABR traffic in ATM networks is described. An enhancement to ERICA scheme was proposed by modifying the target rate depending queue length at switch. From the simulation results presented here, enhanced ERICA scheme gives better ACR for BTEs, no cell drop at switch, and better link utilization than original ERICA scheme. So it has proved that enhanced ERICA gives better than original ERICA scheme.

REFERENCES

- [1] R.S.Deshpande, Dr. P.D. Vyavahare, "Recent Advances and a survey of congestion control mechanisms in ATM networks", IE(I) Journal, Vol. 88, pp. 47-54, , 2007 .
- [2] W Li, Z Che, Y Li, "Research on the congestion control of Broadband Integrated Service Digital Network based on ATM", Proceedings of the fifth international conference on Machine Learning and Cybernetics, Daliaan, pp 2510-2512, 2006.
- [3] E Al-Hammadi and M M Shasavari, "Engineering ATM networks for congestion avoidance", Mobile Networks and Application, Vol. 5, pp.157 – 163, 2000.
- [4] Shivkumar Kalyanaraman, Raj Jain, Sonia Fahmy, Rohit Goyal, and Bobby Vandalore, "The ERICA Switch Algorithm for ABR Traffic Management in ATM networks", IEEE/ACM Transactions on Networking, Vol. 8, Issue 1, pp. 87-98, 2000.
- [5] Ching-Fong Su, Gustavo Do Vacianna, Jean Warland, "Explicit Rate Flow Control for ABR Services in ATM Networks", IEEE/ACM Transactions on Networking, Vol. 8, Issue 3, pp. 350-361, 2000.
- [6] A Hac, H.Lin, "Congestion Control for ABR traffic in an ATM network", International Journal of Network Management, Vol. 9, pp. 249-264, 1999.
- [7] K Siu, H Tzeng, "Intelligent Congestion Control for ABR service in ATM networks",ACM SIGCOMM Computer Communication Review, Vol. 25, Issue 2, pp. 81-106, 1994.
- [8] N Golmie, F Mouveaux, L Hester, Y Saintillan, A Koenig, D.Su, "The NIST ATM/HFC Network Simulator Operation and Programming Guide", Dec 1998.
- [9] H Ohsaki, M Murata, H Suzuki et al, "Rate based Congestion Control for ATM networks", ACM SIGCOMM, Computer Communication Review, Vol. 25, Issue 2, pp. 60-72, 1995.
- [10] J Y. Le Boudec, "The Asynchronous Transfer Mode: A Tutorial", Computer Networks & ISDN Systems, Vol.24, pp. 279-302, 1992.



M. Sreenivasunlu received B.Tech degree in Computer Science and Engineering, from K.L. College of Engineering (K.L.University), Vaddeswaram, A.P. India, in 1990. He completed M.E. in Computer Science & Engineering, from Jadavpur University, Calcutta, India, in 1999. He is having 18 years of teaching experience. He is currently working as Professor & Head of Computer Science and Engineering Department, K.S.R.M.College of Engineering, Kadapa. He is currently pursuing Ph.D.(Part Time) in Computer Science, from JNT University, Anantapur. He is life member of IE(I), and ISTE. He published 5 papers in the proceedings of National and International Conferences.



Dr. E. V. Prasad received B.E. degree in ECE from S.V. University, Tirupati, A.P., India, in 1975. He obtained M.E. in Control Systems from Madras University, Madras, India, in 1978. He received his Ph.D. degree in Computer Science and Engineering, from University of Roorkee (IIT Roorkee) in 1990. He is having 33 years of teaching experience. He received best teacher award from Government of Andhra Pradesh, for the year 2008. During his teaching profession, he worked at different capacities such as Lecturer, Senior Lecturer, Assistant Professor, Professor, Head of Department of CSE, Vice Principal and Principal. Currently he is working as Director, Institute of Science and Technology, J.N.T. University, Kakinada, India. He co-authored three text books. He is life member of ISTE, IE(I), CSI, and IEEE. He has more than 75 research publications in proceedings of National, International Conferences, National and International Journals.



Dr. G.S.S.Raju received M.Sc. degree in Applied Mathematics in 1986, M.Phil. degree in 1987, Ph.D. degree in Mathematics on the topic Study on Hyper Graphs in 1991, from S.V. University, Tirupati, A.P., India. He is having 20 years of teaching experience. Presently he is working as Associate Professor and Head of Mathematics Department, J.N.T. University College of Engineering, Pulivendula, Kadapa, India. He is life member of ISTE. He has more than 16 research publications in National, International Conferences, National and International Journals.