

Modeling Of Management Decisions Of Organization Of Production Systems

Yevhen Arutiunian[†], Olena Mikhailutsa^{††}, Andriy Pozhuyev^{†††}, Maryna Azhazha^{††††},
Iryna Arutiunian[†], Iryna Zrybnieva^{†††††}, Yuliia Slyva^{††††††}

[†] Department of Industrial and Civil Building, Zaporizhzhia National University, Ukraine

^{††} Department of Automation Systems Software, Zaporizhzhia National University, Ukraine

^{†††} Department of General Education, Zaporizhzhia National University, Ukraine

^{††††} Department of Organization Management and Project Management, Zaporizhzhia National University, Ukraine

^{†††††} Department of Marketing, Innovation and Regional Development, Yuriy Fedkovych Chernivtsi National University, Ukraine

^{††††††} Department of Standardization and Certification of Agricultural Products, National University of Life and Environmental Sciences of Ukraine, Ukraine

Summary

Analysis of current state of construction industry functioning in Ukraine allows us to identify a number of problems having negative impact on sustainable development of construction industry, especially in terms of its organization. Therefore, it is absolutely essential to study existing methods of organization system supplying construction sites with necessary material resources. Companies can develop their own logistics departments, which independently solve logistics issues related to transportation organization and management, accounting and inventory management, acquisition and warehousing, intercommunication (ability to obtain both final and intermediate information during transporting materials). Using a complex of methods is substantiated: the hierarchy analysis method (Saati's method), the network method, the defect elimination algorithm DEA, the transportation problem that finds optimal problem solutions for construction sector with the purpose of rational supplying uninterrupted construction with building resources in the designed model "provider-transportation-costs".

Key words: organization system, management decisions, modeling, production systems.

1. Introduction

The study of construction industry functioning in Ukraine in recent years allows us to identify a number of problems that have negative impact on the state of modern construction industry development as a complex organizational, technological and economic system. This has a significant impact on economic development, because construction sector provides efficient production of quality products and services, which is the basis for innovations development.

One of these problems is lack of reliable specialized logistics system that would interconnect the systems of logistics support and assembly of materials and products, and their centralized supply to construction sites. This

situation is determined by the fact that many practical problems of logistics supporting construction production are still insufficiently studied. To solve the problem of production cluster development, we need flexible method of modeling such processes, which reflects communication diversity between suppliers of raw materials, transport conditions, production, products supply, prices. More than that, it is necessary to design models that use objectively sufficient number of variables, reproduce situation essence and do not require much time to form initial modules [1]. In addition, designing system model should not depend on individual factors, it should be universal, when any situation changes will be considered by original data. The model should take into account all interconnections, and its size might be affected only by the number of factors involved [1, 2].

2. Theoretical Consideration

Analysis of current state of construction industry outlined the main ways to solve urgent problems of its development. They lie in making management and organizational decisions meet requirements related to optimal logistics support, coordinated relationships of main construction industry sectors (construction and installation, industrial and production, infrastructure), optimal organization of production process and construction management, unification of construction technologies, implementation and application of information technologies into construction industry sector [3].

Many scientific works of modern scientists are devoted to solving problems related to logistics systems. Their study provided an opportunity to analyze current achievements in the field of issues related to construction industry organization in the context of implementing methodological approaches to

enterprises and organizations management of different industries on the basis of logistics.

Scientific works [4,5,6,7] consider complex variants of travelling salesman problems (TSP) and vehicle routing problems (VRP) in production and service sector. Developed heuristics are evaluated using reference and derived data sets. Paper [8] provides us with broad and relevant concepts overview which lies in the basis of advanced planning system APS. Particular attention is paid to modeling supply chains and successful implementation of APS into industry. Paper [9] provides us with a wide range of resources on many different aspects of supply chain management, including modern programs. It identifies innovative strategies and practical solutions aimed at solving problems faced by enterprise in the process of management supply chain and logistics. General methods and specific approaches to a wide range of important, inspiring and unresolved issues in this area are described in detail.

Researches in construction industry sector enabled us to reveal necessity and relevance of new theoretical and methodological preconditions (new paradigm) in developing strategy for optimizing movements of material flows in the context of changing environment and market transformation. While analyzing tendencies of using logistics approaches for construction industry development, it was defined that logistics is a system of professional performance with high degree of reliability making effective decisions creating new foundations, relationships between industries, taking into account interconnections for construction maintenance including management of material and information flows that accompany them.

The logistics department at the enterprise works closely with production planning units. This is determined by the fact that production depends on timely delivery of raw materials, components in the required quantity and quality. Accordingly, logistics specialists, providing material flow (and, consequently, organization of enterprise supply), should participate in decision-making on products introduction into production [5,6,7].

A great role in timely and quality work performing is played by commercial organizations that organize purchase of material resources. Failure to meet logistics support obligations creates a number of negative factors: construction schedules are disrupted, workers' working time is lost, construction equipment is idle, construction costs increase, and the firm's credibility declines.

Existing system of production and technological supply of construction sites has significant shortcomings, among which an important place is occupied by insufficient communication with suppliers and transport organizations. In order to improve this intercommunication, to ensure effective interaction in the process of providing construction sites with materials and products of enterprises supplying construction organizations, it is necessary to carry out processes of renewal (reforming) of construction organizations performance.

World experience shows that construction industry reforming is carried out more successfully provided that problems of logistics sector have been taken into account. In our opinion, it is relevant today to use logistics management methods at Ukrainian enterprises. Analysis of international experience shows that when using logistics to manage production cluster development in construction industry, terms of implementation are reduced by approximately 20-30%, and costs are reduced by 10-15% [10].

Logistics systems are very diverse according to types of activities at enterprise. For some enterprises, logistics lies in the ability to work with databases, for others – it is a supply or warehousing activity. But according to their purpose (the main of which – is to reduce costs while fulfilling planned tasks, and thus increase efficiency of production activities) logistics systems should cover almost all (except accounting, personnel, etc.) activities [12,13]. Companies can develop their own logistics departments, which independently solve logistics issues related to transportation organization and management, accounting and inventory management, acquisition and warehousing, intercommunication. Further research focuses on problem solving taking into account one of “logistics mix” component of construction logistics – transportation organization and management. Transport logistics is responsible for solving this problem, and its main functions are classification of suppliers and pricing policy.

For clear functioning of transport and logistics system of construction production cluster, it is necessary to build (create) an appropriate structure that will correspond to logistics support of construction production according to technology and organization. From the point of view of mathematics, it is necessary to find optimal solution to the problem of securing construction sites for enterprises of production cluster, using management base of transport and logistics system. Materials and products from each supplier are delivered to the site in the form of route (transport) kit, and after their delivery to the construction site, technological kit is formed [11,12,13] within the project of kit-transport-construction complex.

Logistics tasks complex aimed to achieve defined goals should include scientific substantiation and development of fundamentally new or implementation of previously developed methods that will allow to make decisions based on comprehensive multi-purpose evaluation and selection of successful options for wide practical application. Methods and means that are most common today can be divided into the following groups: mathematical models and mathematical support, organizational, informational and regulatory support, computer technology and automated systems of integrated organization and management.

To solve the problem of multicriteria selection we have used decision support procedure “Analytic hierarchy process” (AHP) [15,16]. Based on it, powerful decision support systems have been developed, such as “Expert choice”.

The hierarchy analysis method is based on paired comparisons of alternatives by different criteria using a special scale of 1 to 9 and subsequent alternatives rating by all criteria and objectives. Relationship between criteria is taken into account by building a hierarchy of criteria and using paired comparisons to identify the importance of criteria and sub-criteria. Using HAM allows to include into the hierarchy all expert-analyst's knowledge and imagination about studied problem. The method is specified being simple, it gives high correspondence to intuitive representations and can be quickly implemented at program level to create fragments of automated decision support systems [15,16].

HAM advantage is due to the following two factors. First, criteria weights and objects evaluation from the point of view of subjective criteria are assigned on the basis of paired comparisons, and not directly as a result of direct will expression. Secondly, criteria are presented in the form of hierarchy because such structure is inherent in concept of "criterion" itself, that means that criteria, taking into account their nature, are hierarchical. Using only criteria values, you can simplify situation by evaluating either for upper levels of criteria tree, or for the lowest. HAM is open to further development and improvement, for example, method adaptation for being used in conditions of uncertainty, conflict and risk caused by them [16].

In order to manage production cluster in the construction industry on the basis of information and analytical training process, it is most rational to apply modern methods and models of logistics systems, which are based on network modeling. Mathematical apparatus of network models is based on graph theory. The basis of network planning and management is network model (NM), which models a set of interconnected works and events that are part of the process of achieving a certain goal. Expanding the boundaries of using network analysis methods allows to solve a wide range of problems [1,2,17]. It enables us to build complex system model like a set of simple systems and to define formal procedures of system qualitative characteristics. In addition, it enables you to design a mechanism for interaction of management system components in order to define main characteristics and determine data necessary for studying system, as well as conduct initial study of management system and make preliminary sequence of its components. On the basis of network models, it is possible to build interrelated process at macro level, to carry out its information analysis, to check its conformity to established criteria and selection rules, to carry out research of the most effective variant. Important difference between network models and linear programming is ability to correct amount of work performed. Network models allow us to study construction logistics without changing topological structure of the graph [1,2, 23].

It allows to expand horizontal economic relations between production cluster enterprises and construction companies, functioning in each region as transport and

construction complex, which general view is shown in the model "supplier-transportation-costs" (Fig. 1).

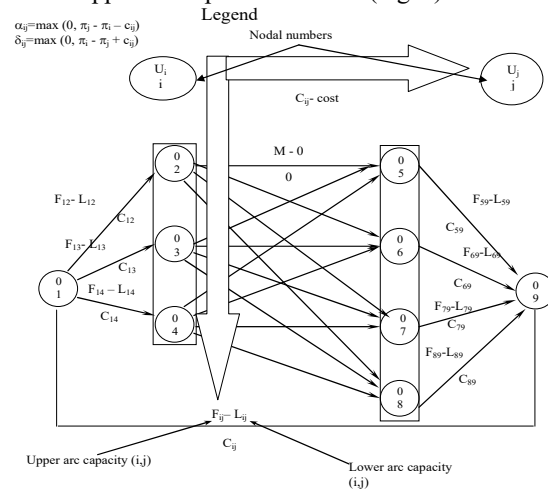

Figure 1. Provider-Transportation-Cost Model

One of the tasks of construction logistics, particularly promotion of material flow (building material, structures, details, semi-finished products) from supplier to construction sites, allows to solve a well-known method of linear programming – the transportation problem, but in classical form a number of factors is not taken into account. It is more correctly to solve general problem of selecting supplier using also the hierarchy analysis method, which will allow to present classical problem in the form of abstract model. Proposed method lies in designing the model based on decision support with the help of hierarchical decomposition of the problem and alternative solutions rating.

In standard problem formulation we are given n supply location, from which products (material flow) can be transported to each of the m consumption location. Productivity of i-th supply location is equal to A_i , and consumption of j-th location – B_j , where A_i and B_j values are fixed in the given planning period. To improve (enhance) classic transportation problem in the context of selecting suppliers, we use HAM. We should determine material transportation scheme for the given planning period when total transportation costs are minimal. Let's take into account that only one type of material is transported [1].

Graphical interpretation of general problem is shown in Figure 2.

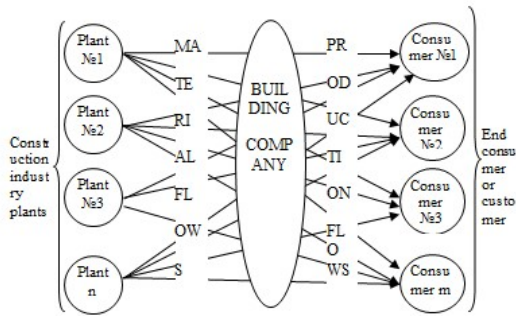

Figure 2. A typical simplified diagram of a transport and logistics system and a production cluster in the construction industry

Designing the model, we will rely on V.I. Sergiev’s experience [18], who selects suppliers using five main criteria: 1) quality (compliance with specifications and consumer expectations, defects percentage); 2) reliability of supplier; 3) price including all costs for supply; 4) quality of service (level of after-sales service, speed of reaction to demands); 5) terms of payment and possibility of unscheduled deliveries. All these criteria may have completely different meanings for different situations, which must be taken into account when obtaining quantitative estimates. Such criteria advantage can be considered the fact that it is suitable both for new supplier evaluation and for evaluation based on experience of cooperation. The only difference will be that evaluation procedure will be based on different sources of information. Alternative approach is presented in Lysons and Gillingham publications [19, 20, 22], who define a number of different criteria for new suppliers and those with whom the buyer has experience of cooperation. For new suppliers, they consider it obligatory to include seven criteria: 1) finance; 2) production facilities and equipment; 3) human resources; 4) quality in broad sense of TQM approach; 5) results of activity; 6) environmental protection and ethical norms; 7) information technology. For the situation of supplier’s activity evaluation on the basis of experience of cooperation Lysons and Gillingham give an example of using four complex criteria, and each of them has the same weight: 1) quality; 2) price; 3) supply; 4) partnership. Each of these indicators is calculated as a combination of directly measurable components, which can be of different weights. Statistics of certain aspects of cooperation with the supplier acts as components.

Based on carried out researches in the field of supplier selection criteria, we have chosen essential from our point of view criteria, and their number can be changed. Let’s consider algorithm work in the following example. Supplier selecting problem will have the following hierarchy model, taking into account the following alternatives and criteria (Fig. 3). Alternatives (suppliers) include the following enterprises: A1 - CJSC “BLOCKS”, A2 - CJSC “ZZHBK №1” (concrete product plant) and A3 - OJSC “PAVLOGRADZHITLOBUD” “Budmeister”. The set of

criteria includes the following six parameters: Specialization (S), Quality (Q), 3) Standby power (SP), Reliability of supply (RS), Funding status (F), Price (P).

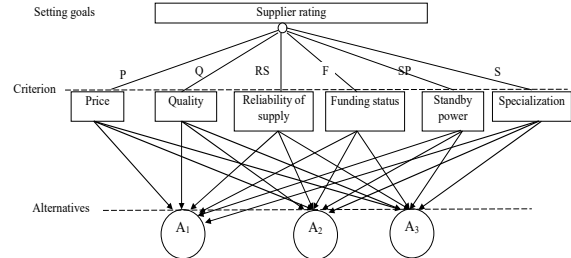

Figure 3. The tree of goals for the problem of modeling the rating of suppliers

Using paired comparisons method with elements evaluation scale, proposed by T. Saati [16], matrix of paired comparisons for selected six criteria is constructed. The results of comparisons are presented in table. 1.

Table 1. Matrix of paired comparisons of the significance of criteria for the problem of selecting suppliers

Compared criteria	Price	Quality	Reliability of supply	Funding status	Standby power	Specialization
Price	1	3	3	4	7	5
Quality	1/3	1	1	3	3	2
Reliability of supply	1/3	1	1	1/3	1/2	3
Funding status	1/4	1/3	3	1	4	1/3
Standby power	1/7	1/3	2	1/4	1	1/3
Specialization	1/5	1/2	1/3	3	3	1

We calculate local priority vectors W_r , using method of determining eigenvector [15, 21]. This requires:

Find maximum eigenvalue λ_r^{\max} of matrix of paired comparisons V_r :

$$\det|V_r - \lambda \cdot E_r| = 0, \tag{1}$$

where E_r – is a unit matrix of dimension $K_r \times K_r$, λ - eigenvalue of matrix V_r .

Let’s solve characteristic equation:

$$(V_r - \lambda_r^{\max} \cdot E_r) \cdot W_r = 0, \tag{2}$$

Under normalization condition:

$$\sum_{k=1}^{K_r} W'_k = 1, \tag{3}$$

$$\text{де } V_r = \begin{pmatrix} v_{11}^r & v_{12}^r & \dots & v_{1K_r}^r \\ v_{21}^r & v_{22}^r & \dots & v_{2K_r}^r \\ \dots & \dots & \dots & \dots \\ v_{K_r,1}^r & v_{K_r,2}^r & \dots & v_{K_r,K_r}^r \end{pmatrix}, W_r = \begin{pmatrix} w_1^r \\ w_2^r \\ \dots \\ w_{K_r}^r \end{pmatrix},$$

$$E_r = \begin{pmatrix} 1 & 0 & \dots & 0 \\ 0 & 1 & \dots & 0 \\ \dots & \dots & \dots & \dots \\ 0 & 0 & \dots & 1 \end{pmatrix}_{K_r \times K_r}, \quad (4)$$

Calculated eigenvector W_r is taken as a local vector of priorities of r -th hierarchy level: $W_r = [0,38 \quad 0,17 \quad 0,10 \quad 0,15 \quad 0,07 \quad 0,13]$.

Suppliers are compared in relation to six characteristics, the corresponding vector of priorities is constructed. Based on suppliers rating, table 2 has been formed.

Table 2. Weighting of each of the above six priority eigenvectors of the corresponding characteristic

	Specialization	Quality	Standby power	Reliability of supply	Funding status	Price
A1	0,33	0,33	0,44	0,41	0,29	0,43
A2	0,33	0,33	0,25	0,32	0,29	0,33
A3	0,33	0,33	0,31	0,27	0,43	0,24

To obtain suppliers rating, we have carried out the procedure of “weighing” of each of the above six priority eigenvectors of the corresponding characteristic (5).

This procedure result is each supplier’s general evaluation: $A1 = 0.36$; $A2 = 0.32$; $A3 = 0.31$. After suppliers rating, classic transportation model is used, which proves general problem solving for the model “supplier-cost” on the basis of using the method of defect elimination algorithm. The scheme of problem solving for the model “supplier-transportation-costs” – logistics system management for implementing programs for production cluster development in the construction sector, taking into account suppliers rating, is presented in Fig. 4.

$$\begin{bmatrix} 0,33 & 0,33 & 0,44 & 0,41 & 0,29 & 0,43 \\ 0,33 & 0,33 & 0,25 & 0,32 & 0,29 & 0,33 \\ 0,33 & 0,33 & 0,31 & 0,27 & 0,43 & 0,24 \end{bmatrix} \times \begin{bmatrix} 0,38 \\ 0,17 \\ 0,10 \\ 0,15 \\ 0,07 \\ 0,13 \end{bmatrix} = \begin{bmatrix} 0,36 \\ 0,32 \\ 0,31 \end{bmatrix}. \quad (5)$$

Conclusions

As a result of performed system research, the system model “supplier-transportation-costs” was designed and tested on the example, which takes into account many different aspects and forms logistics system of supply and transportation. It is substantiated that using system concept enables us to study various aspects of single logistics sector (for example, not only supply system, but also transportation system) in the form of general integrated logistics system.

References

- [1] Arutiunian, I., Dankevych, N., Arutiunian, Y., Saikov, D., Poltavets, M., & Frolov, D. (2020). Development of a mathematical model for selection and rationale for making optimal construction decisions. *Advances in Mathematics: Scientific Journal*, 12(9), 10649-10659.
- [2] Pavlov, I., Poltavets, M., & Pavlov, F. (2018). Systemological management of production systems in construction. *Science of the Daliv University*, 14.
- [3] Tsimoshynska, O., Koval, M., Kryshthal, H., Filipishyna, L., Arsawan, W. E., & Koval, V. (2021). Investing in road construction infrastructure projects under public-private partnership in the form of concession. *Naukovyi Visnyk Natsionalnoho Hirnychoho Universytetu*, 2, 184–192.
- [4] Anbuudayasankar, S., Ganesh, K., & Mohapatra, S. (2014). *Models for Practical Routing Problems in Logistics*. Design and Practices Springer International Publishing.
- [5] Berkuta, A., Osinska, V., Galinsky, O., & Vakhovych, I. (2010). Organizational and economic aspects of foreign experience of self-regulation in construction. *Construction production*, 52, 3-8.
- [6] Krykavsky, E., Pokhilchenko, O., & Furch, M. (2017). *Logistics and supply chain management*. Lviv Polytechnic Publishing House.
- [7] Kozik, V. (2020). *Organization of production: a textbook*. Lviv Polytechnic Publishing House.
- [8] Stadtler, H., Kilger, C., & Meyr, H. (2015). *Supply Chain Management and Advanced Planning: Concepts, Models, Software, and Case Studies*. Springer.
- [9] Liang, Z., Chaovalitwongse, W., & Shi, L. (2016). *Supply Chain Management and*

- Logistics: Innovative Strategies and Practical Solutions. CRC Press.
- [10] Anikin, B., Rodkina, T., Gaponova, M., Puzanova, I., Berezin, D., & Seryshev, R. (2015). Logistics: a tutorial. Prospect.
- [11] Richards, G., & Grinstead, S. (2020). Toolkit for logistics and supply chain management. Axelot.
- [12] Smirnov, I., & Kosareva, T. (2019). Transport logistics: a textbook. Center for Educational Literature.
- [13] Jonsons, J., & Wood, D. (2017). Contemporary Logistics. MacMillan.
- [14] Moller, C., & Johanser, J. (2005). Paradigms in Logistics. Department of Production. University of Aalborg.
- [15] Saati, T. (2008). Decision making with dependencies and feedbacks: Analytical networks. LKI Publishing House.
- [16] Saati, T. (1993). Decision-making: A method for analyzing hierarchies. Radio and Communication.
- [17] Arutiunian, I., Poltavets, M., Bondar, O., Anin, V., & Pavlov, F. (2020). Structural Information Management of Production Systems in Construction. International Journal of Advanced Trends in Computer Science and Engineering, 4(9), 4794-4797.
- [18] Sergeev, V. (2001). Logistics in business: a textbook. INFRA.
- [19] Lysons, K., & Gillingham, M. (2005). Procurement and supply chain management. INFRA.
- [20] M. Iasechko, O. Shelukhin, A. Maranov, S. Lukianenko, O. Basarab, O. Hutchenko (2021). Evaluation of The Use of Inertial Navigation Systems to Improve The Accuracy of Object Navigation. IJCSNS International Journal of Computer Science and Network Security. Vol. 21 No. 3, pp. 71-75.
- [21] S. Piskunov, M. Iasechko, O. Yuhno, N. Polstiana, Y. Gnusov, K. Bashynskiy, A. Kozyr. (2021). Application Of Probability Filter For Maintenance Of Air Objects. IJCSNS International Journal of Computer Science and Network Security. Vol. 21 No. 5, pp. 31-34.
- [22] M. Iasechko, N. Sachaniuk-Kavets'ka, V. Kostrytsia, V. Nikitchenko and S. Iasechko. The results of simulation of the process of occurrence of damages to the semiconductor elements under the influence of multi-frequency signals of short duration, Journal of Critical Reviews, 7(12), 2020, pp. 109 - 112. doi:10.31838/jcr.07.13.18.
- [23] A. Syrotenko, O. Sotnikov M. Iasechko, V. Larin, S. Iasechko O. Ochurenko, and A. Volkov. Model of Combined Solid Plasma Material for the Protection of Radio-Electronic Means of Optical and Radio Radiation, IJATCSE, 8(4), 2019, pp. 1241 — 1247. doi:10.30534/ijatcse/2019/33842019.