

# Channel Transfer Function estimation based on Delay and Doppler Profiler for 5G System Receiver targeting 500km/h linear motor car

Suguru Kuniyoshi<sup>1)</sup>, Shiho Oshiro<sup>2)</sup>, Gennan Hayashi<sup>3)</sup> and Tomohisa Wada<sup>4)</sup>

1) Magna Design Net Inc., 3-1-15 Maejima, Naha-shi, Okinawa, Japan

2) Information Technology Center, University of the Ryukyus, Okinawa, Japan

3) Graduate School of Engineering and Science University of the Ryukyus, Senbaru 1, Nishihara, Okinawa, Japan

4) Dept. of Engineering, University of the Ryukyus, Senbaru 1, Nishihara, Okinawa, Japan

## Summary

A 500 km/h linear motor high speed terrestrial transportation service is planned to launch 2027 in Japan. In order to support 5G service in the train, the Sub-carrier spacing frequency of 30 kHz is planned to be used instead of common 15 kHz sub-carrier spacing to mitigate Doppler effect in such high-speed transportation.

In addition, to increase the cell size of 5G mobile system, plural Base Station antenna will transmit the identical Down Link (DL) signal to form the expanded cell size along the train rail. In this situation, forward and backward antenna signals will be Doppler shifted by reverse direction respectively and the receiver in the train might suffer to estimate accurate Channel Transfer Function (CTF) for its demodulation.

In this paper, Delay and Doppler Profiler (DDP) based Channel Estimator is proposed and it is successfully implemented in signal processing simulation system. Then the simulated performances are compared with the conventional Time domain linear interpolated estimator. According to the simulation results, QPSK modulation can be used even under severe channel condition such as 500 km/h, 2 path reverse Doppler Shift condition, although QPSK modulation can be used less than 200 km/h with conventional Channel estimator.

## Keywords:

5G, 5th Generation Mobile Communication System, Channel estimation

## I. Introduction

A 500 km/h linear motor high speed terrestrial transportation service is planned to launch 2027 between Tokyo and Nagoya in Japan. The maximum speed of current high speed train Shinkansen is 300 km/h. However, the coming linear motor train's speed will be 500 km/h by using magnetic levitation mechanism. In order to support 5G service in the train, 5G will use some different configurations. First, increased sub-carrier spacing  $f_0$  of 30 kHz is used instead of conventional 15 kHz to mitigate Doppler frequency shift. This change automatically shortens OFDM symbol length by half. Consequently, channel state change tracking performance will increase. Second, to increase mobile

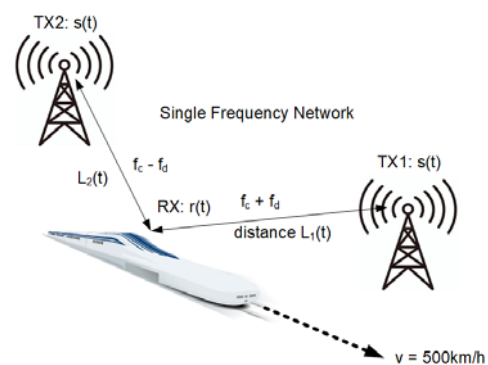

Fig. 1: Two Down Link receiving situation in the high-speed train

service cell size, plural Base Station antennas transmit the identical Down Link (DL) signal to form the expanded cell size along the train rail. In this situation, forward and backward antenna signals will be Doppler shifted by reverse directions respectively and the receiver in the train might suffer to estimate accurate Channel Transfer Function (CTF) for demodulation. Fig. 1 shows the situation of two Down Link (DL) reception in the car. Approaching TX1 antenna signal is  $+f_d$  shifted and backward TX2 signal is  $-f_d$  shifted.

In this paper, in order to improve the receiver performance, Delay and Doppler Profiler (DDP) based estimation method of Channel Transfer Function (CTF), which varies along with the train movement, is applied. In section II, first, targeting 5G Mobile Communication System is briefly shown. Then the proposed DDP method is explained. Computer simulation results are shown in section III. Finally, in section IV, the conclusions will be given.

Table 1: 5th Generation Mobile Communication System Parameters

Parameters	Value
System Band Width	100 MHz
Sub-carrier Spacing ( $f_0$ )	30 kHz
Pass Band Frequency	3.9 GHz
OFDM symbol length (T)	33.33 us (4096 points)
Number of Common Resource Blok (CRB)	273
Number of Sub-carriers	3276
Sampling Frequency ( $F_s$ )	122.88 Msps
FFT size	4096
CP length	352 or 288 points

## II. 5G Mobile Communication System Architecture

5th Generation Mobile Communication System [1] is OFDM communication system standard developed as the successor to the 4G system with various enhancements. For example, the sub-carrier spacing was fixed as 15kHz in 4G but in 5G variable sub-carrier spacing is supported such as 15 / 30 / 60 / 120 / 240 kHz. For the application of the linear motor train, 30 kHz sub-carrier frequency will be used for RF Carrier of 3.9 GHz Band. Table I summaries the 5G system parameters for this application. To support eMBB (enhanced Mobile Broadband), 100MHz bandwidth is assumed with 3276 sub-carriers. Because of sub-carrier spacing  $f_0$  of 30 kHz, OFDM symbol length T of 33.33us (4096 sampling points) is used.

Fig. 2 shows the 5G Frame structure for  $f_0$  of 30 kHz. 10 ms Frame is divided into 20 Slots. In one Slot, 14 OFDM symbols are embedded. Cyclic prefix (CP) length is 288 sampling points for each 4096 points OFDM symbols except the 1<sup>st</sup> CP. The length of the 1<sup>st</sup> CP is a little expanded such as 352 points. In 5G system, Demodulation Reference Signals (DMRS) are inserted to

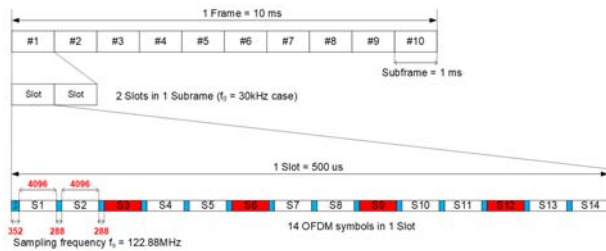

Fig. 2: 5G Frame structure

some Sub-carriers to measure Channel Transfer Function (CTF) and the DMRS can be placed with a high degree of freedom according to the system configuration. This time, DMRS is asserted in S3, S6, S9, S12 OFDM symbols to detect rapidly time-domain changing CTF [2]. Time-Frequency structure of this 5G system is shown in Fig. 3. Since 12 sub-carriers and 14 OFDM symbols constitute one Common Resource Block (CRB), the total 3276 sub-carriers correspond to 273 CRBs. The detail of sub-carrier arrangement in a CRB is also shown in the figure. For frequency direction (vertically), DMRS are placed every 2 sub-carriers as shown in the odd number places. Sub-carriers at the odd number in S3, S6, S9, S12 OFDM symbols are empty, although those empties might be used for MIMO configurations system with multiple antennas.

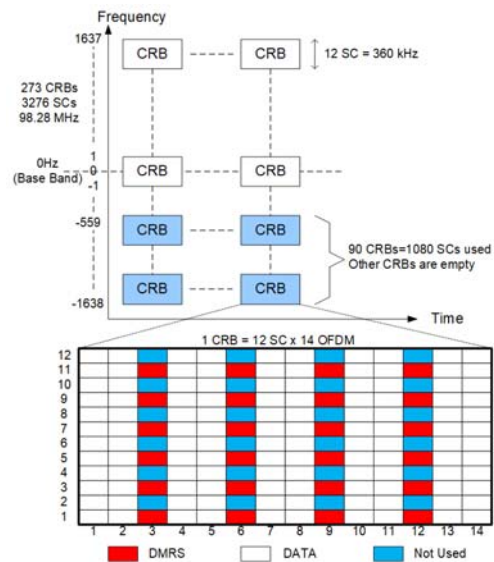

Fig. 3: Time-Frequency structure of System

### A) Physical layer of 5G communication system

Fig. 4 shows the block diagram of the Physical Layer (PHY) for 5G SISO (Single Input Single Output) system. The upper side is the transmitter and the lower side is the receiver. The Bit Data, which are provided from the upper MAC, Protocol and Application layer, are digital modulated at Symbol mapper by QPSK / 16QAM / 64 QAM / 256 QAM. Then the modulated symbols and DMRS pilots signals configure Slots as shown in Fig. 3. Then Inverse 4096 points Fourier Transform (IFFT) is performed as OFDM modulation and Cyclic Prefix (CP)

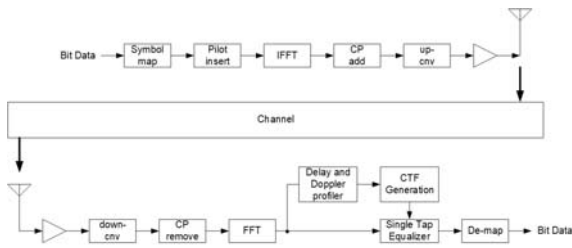

Fig. 4: Physical layer of 5G communication system

is appended. This signal is Baseband (BB) signal. By applying up-conversion to BB signal, path-band signal is generated then emitted through power amplifier and antenna.

The receiver side performs basically the reverse process of the transmitter. However, since the receiving signal is distorted through the propagation channel, Channel Transfer Function (CTF), which is a Frequency domain representation of Channel Impulse Response in Time domain, has to be estimated and the distortion has to be compensated at Equalizer using the estimated CTF. Then the accuracy of the CTF estimation greatly influence to the receiver error performance. In conventional 5G receiver, the measured CTF values at the DMRS position are interpolated in Frequency and Time domain to get all sub-carrier position CTF. In order to improve CTF estimation, this paper studies new method such as Delay and Doppler Profiler based all CTF estimation.

**B) Improved Channel Transfer Function estimation based on Delay and Doppler Profile**

References [3-5] describe detail methods of Delay and Doppler Profile (DDP) based CTF estimation using pilot signals embedded in OFDM sub-carriers. Fig. 5 is a

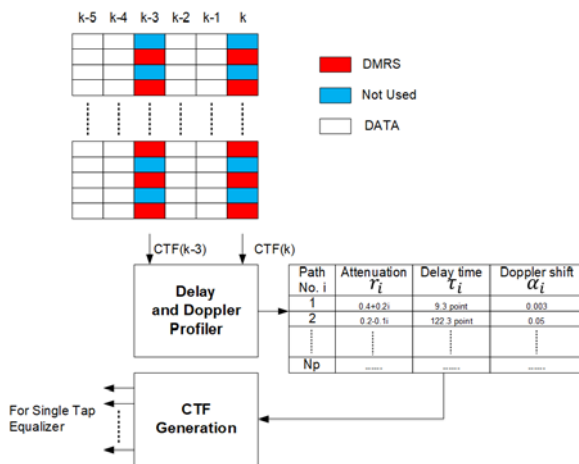

Fig. 5: Delay and Doppler Profiler based CTF estimator

block diagram of proposed DDP CTF generation. The upper side of the figure represents the Time-Frequency structure of sub-carriers with time-domain symbol index  $k$ . The DDP estimates each  $N_p$  multipath component waves to receiving antenna. Each analyzed component can be characterized using three parameters such as Attenuation  $r_i$ , Propagation Delay time  $\tau_i$ , and normalized Doppler shift  $\alpha_i$  for wave component index  $i$ . Here the Attenuation  $r_i$  is complex value including amplitude attenuation and phase rotation and the normalized Doppler shift is normalized by sub-carrier spacing  $f_0$  such as  $\alpha_i = fd_i/f_0$ . Using the symbol  $k$  measured CTF( $k$ ) and symbol  $k-3$  measured CTF( $k-3$ ), the DDP detects  $N_p$  sets of those three parameters. Using those parameters, all position CTF  $h(k, l)$  can be calculated as Equation (1). Here,  $k$  is symbol number,  $l$  is sub-carrier index,  $N$  is the FFT size,  $N_p$  is the total number of delay paths,  $T_s$  is the sum of OFDM symbol length and CP length.

$$h(k, l) = \sum_{i=1}^{N_p} \frac{1}{N} \frac{\sin\{\pi(\alpha_i)\}}{\sin\{\frac{\pi(\alpha_i)}{N}\}} \times e^{j\frac{\pi(N-1)\alpha_i}{N}} \times e^{j2\pi\alpha_i f_0 T_s k} \times r_i e^{-j2\pi f_0(l+\alpha_i)\tau_i} \dots (1)$$

Once Delay and Doppler profile parameters are known, by changing the symbol number  $k$ , CTF at different times can be generated.

The method of obtaining the parameters in each delay path by DDP is detailed in references [3-5], but now DMRS pilots are inserted at symbol numbers  $k$  and  $k - 3$ . Consider the following estimated evaluation function  $E(k)$ . CTF is measured at DMRS pilots,  $h$  is the channel transfer function to estimate by minimizing  $E(k)$ . Summation range  $P$  corresponds sub-carrier indexes on DMRS positions.

$$E(k) = \sum_{l=P}^{|CTF(k, l) - h(k, l)|^2} + \sum_{l=P}^{|CTF(k - 3, l) - h(k - 3, l)|^2} \dots (2)$$

First, the maximum power delayed wave is detected by minimizing the following equation.

$$E_1(k) = \sum_{l=P}^{|CTF(k, l) - f(\alpha_1)r_1 e^{-j2\pi f_0(l+\alpha_1)\tau_1}|^2} + \sum_{l=P}^{|CTF(k - 3, l) - f(\alpha_1)r_1 e^{-j2\pi f_0(l+\alpha_1)\tau_1}|^2} \dots (3)$$

where  $f(\alpha_1)$  is given by

$$f(\alpha_i) = \frac{1}{N} \frac{\sin\{\pi(\alpha_i)\}}{\sin \frac{\pi(\alpha_i)}{N}} \times e^{j\frac{\pi(N-1)\alpha_i}{N}} \times e^{j2\pi\alpha_i f_0 T_s k} \quad \dots (4)$$

According to [3-5],  $r_1$ ,  $\tau_1$ , and  $\alpha_1$  can be obtained by minimizing  $E_1(k)$ . This yields the channel transfer function of the first pass ( $i=1$ ) according to equation (1).

By subtracting the obtained channel transfer function of the first pass from the measured CTF, remaining CTF value can be obtained, and the same calculation is performed to obtain the parameters of the second pass. By repeating the above calculations  $N_p$  times, all parameters for each pass can be obtained. Once the parameters of all  $N_p$  paths are known, all CTF such as  $h(k, l)$  according to equation (1) can be synthesized, and by varying the symbol number  $k$ , channel transfer functions corresponding to  $k$  from  $k-5$  can be obtained.

### III. Computer Simulations

Since the actual test environment is not yet available, computer simulations were used to simulate the environment. Fig. 6 shows a computer simulated running linear motor train situation. Nearby Base Station (gNB: g Node B in 5G notation) antennas are located from the train rail by  $D$  (m). In a Single Frequency Network (SFN), the same DL signal is transmitted from antennas in different each gNBs. Communication area is assumed then The distance of two antennas is 300 m between gNBs. Assuming the location of the reception antenna as  $X_r(t)$  of horizontal x-axis as shown in the figure. The distances between two antennas and the receiver antenna are  $L1(t)$  and  $L2(t)$  as shown in the figure (Fig. 6).

More detail of simulation parameters is listed in Table 2. Assumed Radio passband frequency is 3.9 GHz. In the simulation, moving train will start receiving 4 frames of DL signal with  $X_r(t=0) = -50$  m. Path1 DL signal comes from forward antenna with varying length  $L1(t)$  with relative amplitude gain = 1.0. Path2 DL signal comes from backside with  $L2(t)$  distance with relative

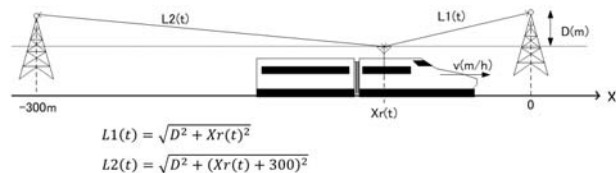

Fig. 6: Simulated vehicle moving situation

Table 2: Simulation Parameters

Parameters	Value
RF pass band frequency	3.9 GHz
Modulation	QPSK / 16QAM / 64QAM / 256QAM
RX moving speed	0 km/h ~ 500km/h, (100km/h step)
CNR	Add to AWGN -10 dB ~ 50 dB, (1 dB step)
Number of Frames	4 Frames (40 ms, 80 slots)
Used number of CRBs	90 CRBs (1080 Sub-carriers)
Channel	SISO, 2 Paths, Single Frequency Network
Path1 (L1(t))	Distance = ~50m Amp gain = 1.0
Path2 (L2(t))	Distance = ~250m Amp gain = 0.5
Antenna Distance (D)	D = 2 m

amplitude gain = 0.5. Bit Error Rate (BER) is measured in lower frequency 90 CRBs as shown in Fig. 3.

The Bit Error Rate (BER) was obtained by adding Additive White Gaussian Noise (AWGN) to the signal received as a composite wave of the 2gNB-derived Down Link (DL) signal, varying from -10 dB to 50 dB in 1 dB steps.

Simulated results for QPSK / 16QAM / 64QAM / 256QAM BER with Carrier to Noise Ratio (CNR) were shown in Figs. 7-10. In each figure, (a) corresponds to conventional linearly interpolated CTF estimation and (b) corresponds to proposed DDR based CTF estimation. Figs. 11-14 show BER vs train moving speed for QPSK with CNR=16dB, 16QAM with CNR=23dB, 64QAM with CNR=30dB and 256QAM with CNR=30dB.

Assuming BER below 1.0E-03 can be error correctable with associated error correction mechanism, QPSK modulation can be used even under severe channel condition such as 500 km/h with 2 path reverse Doppler Shift condition, although QPSK modulation with conventional Channel estimator can be used less than 200 km/h. For 16QAM modulation, roughly 150km/h limitation is extended to double speed of 300km/h. For 64QAM case, the limitation speed is improved from below 100km/h to 150km/h. For 256QAM modulation, only small improvement has been confirmed.

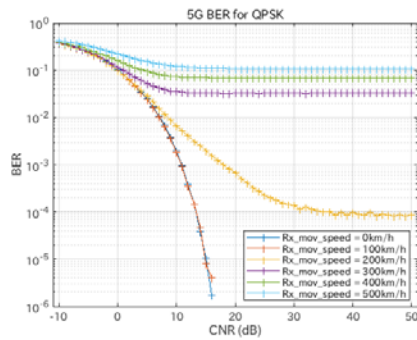

(a) Conventional CTF Linear Interpolator

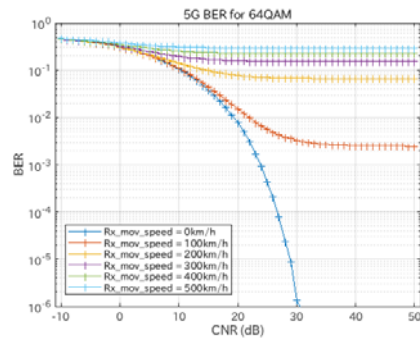

(a) Conventional CTF Linear Interpolator

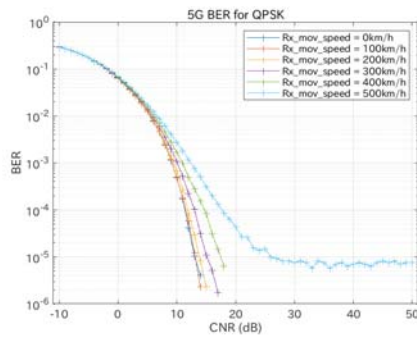

(b) Delay and Doppler Profiler based CTF

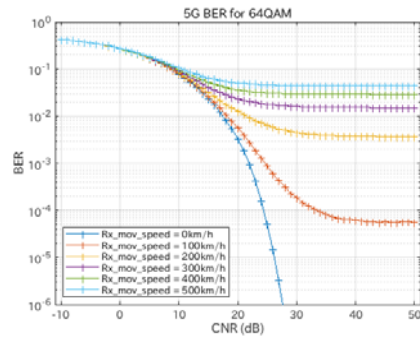

(b) Delay and Doppler Profiler based CTF

Fig. 7: BER vs CNR (dB) for QPSK modulation

Fig. 9: BER vs CNR (dB) for 64QAM modulation

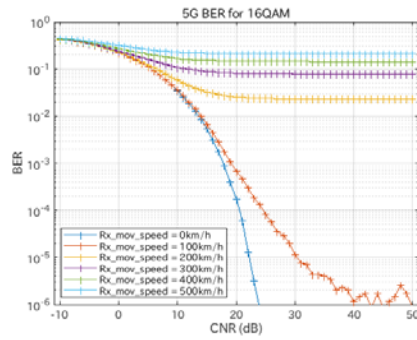

(a) Conventional CTF Linear Interpolator

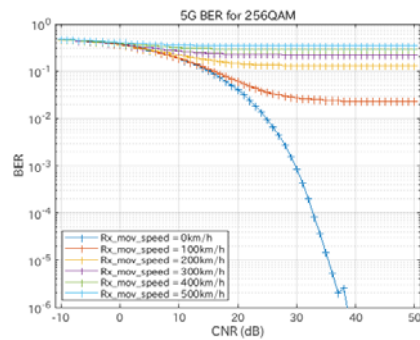

(a) Conventional CTF Linear Interpolator

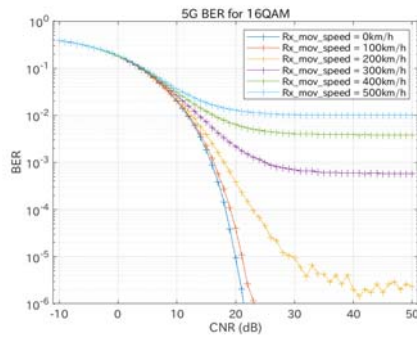

(b) Delay and Doppler Profiler based CTF

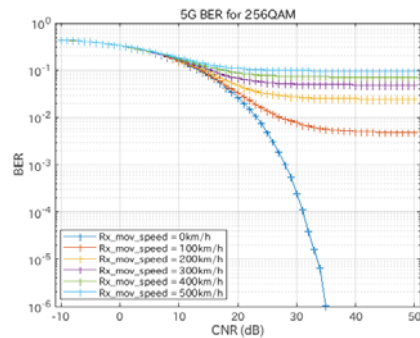

(b) Delay and Doppler Profiler based CTF

Fig. 8: BER vs CNR (dB) for 16QAM modulation

Fig. 10: BER vs CNR (dB) for 256QAM modulation

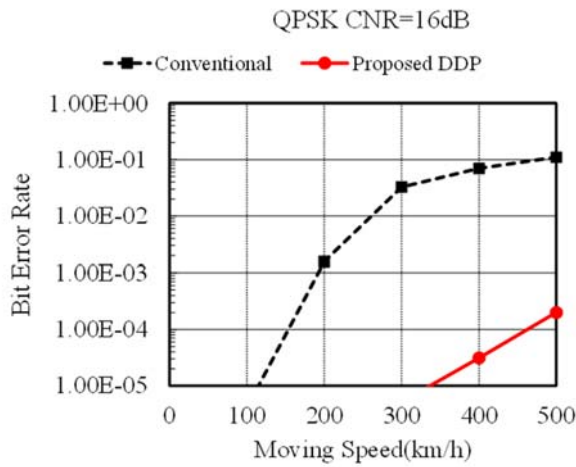

Fig. 11: BER vs Moving Speed for QPSK

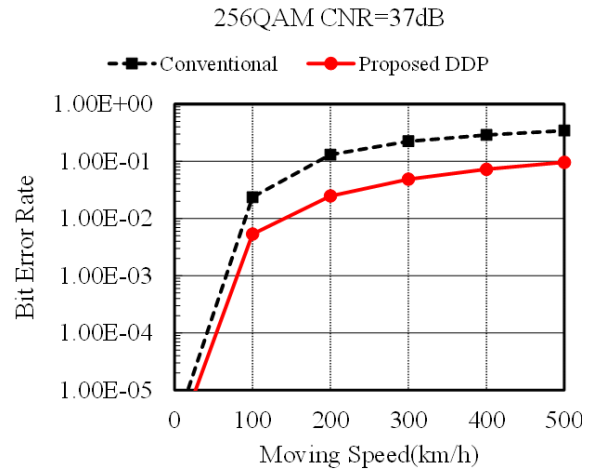

Fig. 14: BER vs Moving Speed for 256QAM

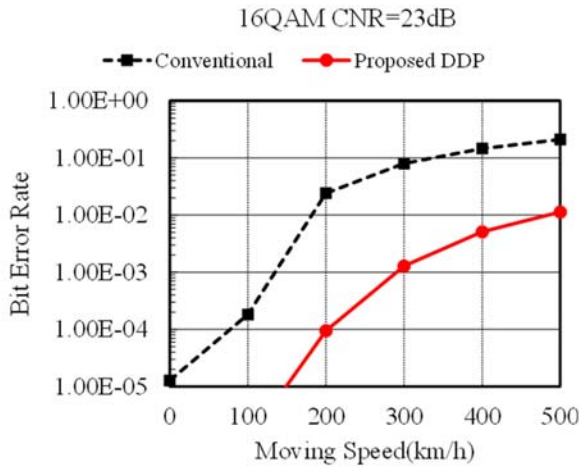

Fig. 12: BER vs Moving Speed for 16QAM

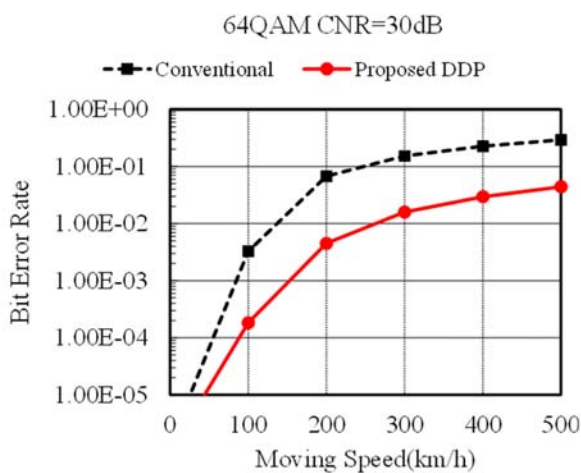

Fig. 13: BER vs Moving Speed for 64QAM

### IV. Conclusion

Delay and Doppler Profiler (DDP) based Channel Estimator is proposed targeting 500km/h train support and it is successfully implemented in signal processing simulation system. Simulated performances are compared with the conventional Time domain linear interpolated estimator. According to the simulation results, QPSK modulation can be used even under severe channel condition such as 500 km/h, 2 path reverse Doppler Shift condition, although QPSK modulation can be used less than 200 km/h with conventional Channel estimator. For 16QAM modulation, roughly 150km/h limitation is extended to double speed of 300km/h. For 64QAM case, the limitation speed is improved from below 100km/h to 150km/h. For 256QAM modulation, only small improvement has been confirmed.

### References

- [1] 3GPP TS38.211 V17.4.0 : “3rd Generation Partnership Project; Technical Specification Group Radio Access Network; NR; Physical channels and modulation” Dec. 2022.
- [2] Erik Dahlman, Stefan Parkvall, Johan Sköld (2021). *5G NR THE NEXT GENERATION WIRELESS ACCESS TECHNOLOGY SECOND EDITION*. Academic Press.
- [3] Mitsuru Nakamura, Makoto Itami, Kohji Itoh and Hamid Aghvami, “ICI Cancellation Technique based on Estimating Delay and Doppler Profile in OFDM Reception,” *The Institute of Image Information and Television Engineers*, Vol. 56, No. 12, pp.1951-1958 (2002).
- [4] Mitsuru Nakamura, Masahiro Fujii, Makoto Itami and Kohji Itoh, “MMSE ICI Canceller for OFDM Mobile

Reception,” The Institute of Image Information and Television Engineers, Vol. 58, No. 1, pp.83-90 (2004).

- [5] Akito Yamazaki, Mitsuru Nakamura, Masahiro Fujii, Makoto Itami, Kohji Itoh and Hiroki Ohta, “A Study on Improving Performance of an OFDM ICI Canceller,” The Institute of Image Information and Television Engineers, Vol. 58, No. 1, pp.94-101 (2005).



**Suguru Kuniyoshi** received the B.E. and M.E. degrees, from the University of the Ryukyus, Okinawa, Japan in 2004 and 2006, respectively. He joined Magna Design Net, Inc. in 2006 and has engaged with digital signal processing design of modulator and demodulator part for a Wireless

LAN, WiMAX, 4G-LTE, 5G-NR, and underwater communication. Currently he is the Engineering Manager of the Development Department at Magna Design Net, Inc.



**Shiho Oshiro** received the B.E. and M.E. degrees, from the University of the Ryukyus, Okinawa, Japan in 2018 and 2020, respectively. She received the Dr. Eng. degree from University of the Ryukyus in 2023. She has been an assistant professor at University of the Ryukyus since 2023.

She has experienced short-term study abroad at Madan Mohan Malaviya University of Technology (MMMUT) Gorakhpur and Atal Bihari Vajpayee-Indian Institute of Information Technology and Management (ABV-IIITM) Gwalior in India, Institute of Technology of Cambodia (ITC) in Cambodia, and National Taiwan University of Science and Technology (Taiwan Tech). Her research interest includes Underwater OFDM Acoustic communication systems, developed Underwater Acoustic OFDM wireless communication systems, Underwater Acoustic Positioning systems targeting for Underwater Drone controls, Flight Control for Underwater Drone automatically controls, and Autoencoder for OFDM communication system.



**Gennan Hayashi** graduated at the Area of Computer Science and Intelligent Systems course in the Faculty of Engineering at the University of the Ryukyus, Okinawa, Japan in 2023. He is now a master’s student at the Graduate School of Engineering and Science at the

University of Ryukyus. Since 2022, he joined Prof. Wada’s laboratory and engages in the research related to 5G mobile communication system.



**Tomohisa Wada** received B.S. degree in electronic engineering from Osaka University, Osaka, Japan, in 1983, M.S.E.E. degree from Stanford University, Stanford CA, in 1992, and Ph.D. in electronic engineering from Osaka University in 1994. He joined the ULSI Laboratory, Mitsubishi

Electric Corp. Japan in 1983 and engaged in the research and development of VLSI such as High-speed Static Random-access memories, Cache memories for Intel MPUs in 16 years. Since 2001, he has been a Professor at the Department of Information Engineering, the University of the Ryukyus, Okinawa, Japan. In 2001, He was the founding member of Magna Design Net, Inc., which is a fab-less LSI design Company for communication related digital signal processing such as OFDM. Currently, he is also the chief scientist of Magna Design Net, Inc. who is engaging in the research and development of a terrestrial video broadcasting receiver, a wireless LAN, WiMAX, 4G-LTE and 5G systems. After 2009, he also started Underwater OFDM Acoustic communication systems and developed Underwater Acoustic OFDM wireless communication systems and Underwater Acoustic Positioning systems targeting for Underwater Drone controls.