

# Experiment in the PBNM Scheme for Multiple Domains as Cyber Physical System Using Data Science and AI

Kazuya Odagiri,<sup>†</sup> Shogo Shimizu<sup>††</sup>, Naohiro Ishii<sup>†††</sup>

<sup>†</sup> Sugiyama Jogakuen University, 464-8662, 17-3Hosigaokamotomachi Chiksa-ku, Nagoya, Aichi, Japan

<sup>††</sup> Gakushuin Women's College, Tokyo, Japan

<sup>†††</sup> Advanced Institute of Industrial Technology, Tokyo, Japan

## Summary

In the current Internet system, there are many problems using anonymity of the network communication such as personal information leaks and crimes using the Internet system. This is why TCP/IP protocol used in Internet system does not have the user identification information on the communication data, and it is difficult to supervise the user performing the above acts immediately. As a study for solving the above problem, there is the study of Policy Based Network Management (PBNM). This is the scheme for managing a whole Local Area Network (LAN) through communication control for every user. In this PBNM, two types of schemes exist. As one scheme, we have studied theoretically about the Destination Addressing Control System (DACS) Scheme with affinity with existing internet. By applying this DACS Scheme to Internet system management, we will realize the policy-based Internet system management. In this paper, basic system design for PBNM scheme for multi-domain management utilizing data science and AI is showed with experiment in feasibility.

## Keywords:

*Policy-based network management; DACS Scheme; QOS*

## 1. Introduction

In the current Internet system, there are many problems using anonymity of the network communication such as personal information leaks and crimes using the Internet system. As a study for solving the problems, Policy Based Network Management (PBNM) [2] exists. The PBNM is a scheme for managing a whole Local Area Network (LAN) through communication control every user, and cannot be applied to the Internet system. This PBNM is often used in a scene of campus network management. In a campus network, network management is quite complicated. Because a computer management section manages only a small portion of the wide need of the campus network, there are some user support problems. For example, when mail boxes on one server are divided and relocated to some different server machines, it is necessary for some users to

update a client machine's setups. Most of computer network users in a campus are students. Because students do not check frequently their e-mail, it is hard work to make them aware of the settings update. This administrative operation is executed by means of web pages and/or posters. For the system administrator, individual technical support is a stiff part of the network management. Because the PBNM manages a whole LAN, it is easy to solve this kind of problem. In addition, for the problem such as personal information leak, the PBNM can manage a whole LAN by making anonymous communication non-anonymous. As the result, it becomes possible to identify the user who steals personal information and commits a crime swiftly and easily. Therefore, by applying the PBNM, we will study about the policy-based Internet system management.

In the existing PBNM, there are two types of schemes. The first is the scheme of managing the whole LAN by locating the communication control mechanisms on the path between network servers and clients. The second is the scheme of managing the whole LAN by locating the communication control mechanisms on clients. As the second scheme, we have studied theoretically about the Destination Addressing Control System (DACS) Scheme. As the works on the DACS Scheme, we showed the basic principle of the DACS Scheme, and security function [14]. After that, we implemented a DACS System to realize a concept of the DACS Scheme. By applying this DACS Scheme to Internet system, we will realize the policy-based Internet system management. Then, the Wide Area DACS system (wDACS system) [15] to use it in one organization was showed as the second phase for the last goal. As the first step of the second phase, we showed the concept of the cloud type virtual PBNM, which could be used by plural organizations [16]. In this paper, to realize it, basic system design for PBNM scheme for multi-domain management utilizing data science and AI is proposed. In Section 2, motivation and related research for this study are described. In Section 3, the existing DACS Scheme is described. In Section 4, basic system design for the proposed system is showed with experiment in feasibility.

## 2. Motivation and Related Research

In the current Internet system, problems using anonymity of the network communication such as personal information leak and crimes using the Internet system occur. Because TCP/IP [1] protocol used in Internet system does not have the user identification information on the communication data, it is difficult to supervise the user performing the above acts immediately. However, it becomes possible to use PBNM, which has two types of schemes. The first scheme is the scheme described in Figure 1. The standardization of this scheme is performed in various organizations. In IETF, a framework of PBNM [2] was established. Standards about each element constituting this framework are as follows. As a model of control information stored in the server called Policy Repository, Policy Core Information model (PCIM) [3] was established. After it, PCMIe [4] was established by extending the PCIM. To describe them in the form of Lightweight Directory Access Protocol (LDAP), Policy Core LDAP Schema (PCLS) [5] was established. As a protocol to distribute the control information stored in Policy Repository or decision result from the PDP to the PEP, Common Open Policy Service (COPS) [6] was established. Based on the difference in distribution method, COPS usage for RSVP (COPS-RSVP) [7] and COPS usage for Provisioning (COPS-PR) [8] were established. RSVP is an abbreviation for Resource Reservation Protocol. The COPS-RSVP is the method as follows. After the PEP having detected the communication from a user or a client application, the PDP makes a judgmental decision for it. The decision is sent and applied to the PEP, and the PEP adds the control to it. The COPS-PR is the method of distributing the control information or decision result to the PEP before accepting the communication.

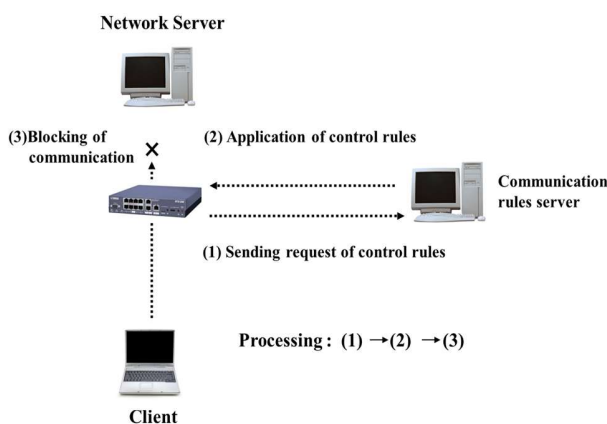

Figure 1. Principle in First Scheme

Next, in DMTF, a framework of PBNM called Directory-enabled Network (DEN) was established. Like the IETF framework, control information is stored in the

server storing control information called Policy Server, which is built by using the directory service such as LDAP [9], and is distributed to network servers and networking equipment such as switch and router. As the result, the whole LAN is managed. The model of control information used in DEN is called Common Information Model (CIM), the schema of the CIM (CIM Schema Version 2.30.0) [11] was opened. The CIM was extended to support the DEN [10], and was incorporated in the framework of DEN.

In addition, Resource and Admission Control Subsystem (RACS) [12] was established in Telecoms and Internet converged Services and protocols for Advanced Network (TISPAN) of European Telecommunications Standards Institute (ETSI), and Resource and Admission Control Functions (RACF) was established in International Telecommunication Union Telecommunication Standardization Sector (ITU-T) [13].

However, all the frameworks explained above are based on the principle shown in Figure 1. As problems of these frameworks, two points are presented as follows. Essential principle is described in Figure 2. To be concrete, in the point called PDP (Policy Decision Point), judgment such as permission and non-permission for communication pass is performed based on policy information. The judgment is notified and transmitted to the point called the PEP, which is the mechanism such as VPN mechanism, router and Fire Wall located on the network path among hosts such as servers and clients. Based on that judgment, the control is added for the communication that is going to pass by.

The principle of the second scheme is described in Figure 3. By locating the communication control mechanisms on the clients, the whole LAN is managed. Because this scheme controls the network communications on each client, the processing load is low. However, because the communication control mechanisms need to be located on each client, the work load becomes heavy.

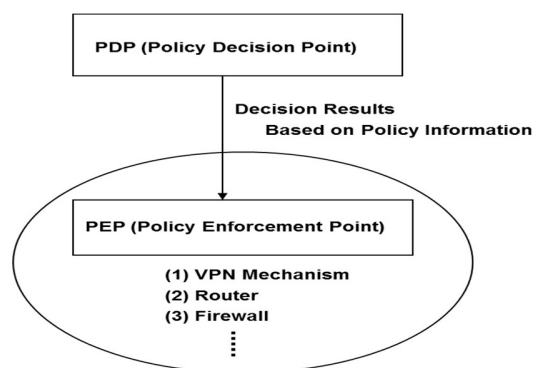

Figure 2. Essential Principle

When it is thought that Internet system is managed by using these two schemes, it is difficult to apply the first scheme to Internet system management practically. This is why the communication control mechanism needs to be

located on the path between network servers and clients without exception. On the other hand, the second scheme locates the communication controls mechanisms on each client. That is, the software for communication control is installed on each client. So, by devising the installing mechanism letting users install software to the client easily, it becomes possible to apply the second scheme to Internet system management. As a first step for the last goal, we showed the Wide Area DACS system (wDACS) system [15]. This system manages a wide area network, which one organization manages. Therefore, it is impossible for plural organizations to use this system. Then, as the next step, we showed the cloud type virtual PBNM, which could be used by plural organizations in this paper.

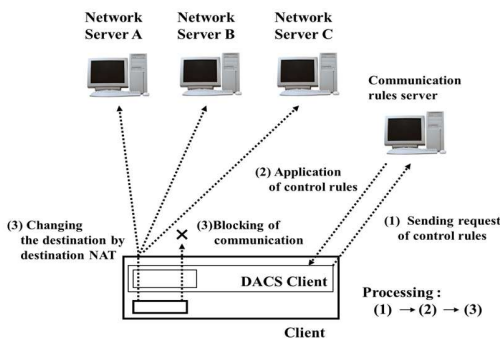

Figure 3. Principle in Second Scheme

### 3. Existing DACS SCHEME and wDACS System

In this section, the content of the DACS Scheme which is the study of the phase 1 is described.

#### 3.1 Basic Principle of the DACS Scheme

Fig.4 shows the basic principle of the network services by the DACS Scheme. At the timing of the (a) or (b) as shown in the following, the DACS rules (rules defined by the user unit) are distributed from the DACS Server to the DACS Client.

- (a) At the time of a user logging in the client.
- (b) At the time of a delivery indication from the system administrator.

According to the distributed DACS rules, the DACS Client performs (1) or (2) operation as shown in the following. Then, communication control of the client is performed for every login user.

- (1) Destination information on IP Packet, which is sent from application program, is changed.

- (2) IP Packet from the client, which is sent from the application program to the outside of the client, is blocked.

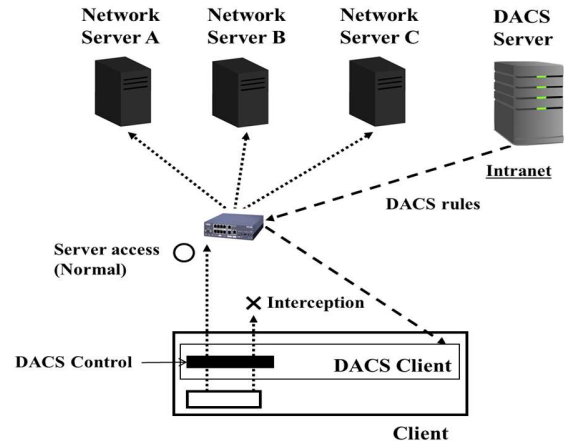

Fig. 4 Basic Principle of the DACS Scheme

An example of the case (1) is shown in Fig.4. In Fig.4, the system administrator can distribute a communication of the login user to the specified server among servers A, B or C. Moreover, the case (2) is described. For example, when the system administrator wants to forbid an user to use MUA (Mail User Agent), it will be performed by blocking IP Packet with the specific destination information.

In order to realize the DACS Scheme, the operation is done by a DACS Protocol as shown in Fig.5. As shown by (1) in Fig.5, the distribution of the DACS rules is performed on communication between the DACS Server and the DACS Client, which is arranged at the application layer. The application of the DACS rules to the DACS Control is shown by (2) in Fig.5.

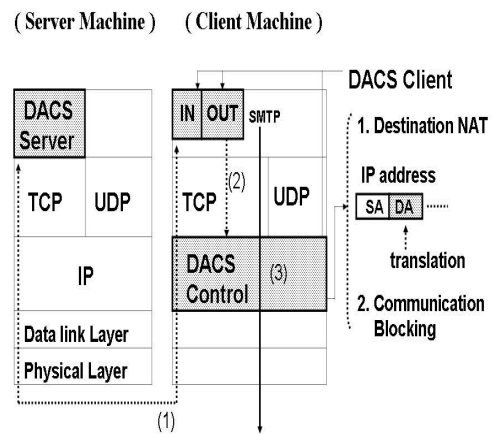

Fig.5 Layer Setting of the DACS Scheme

The steady communication control, such as a modification of the destination information or the communication

blocking is performed at the network layer as shown by (3) in Fig.5.

### 3.2 Application to cloud environment

In this section, the contents of wDACS system are explained in Figure 6.

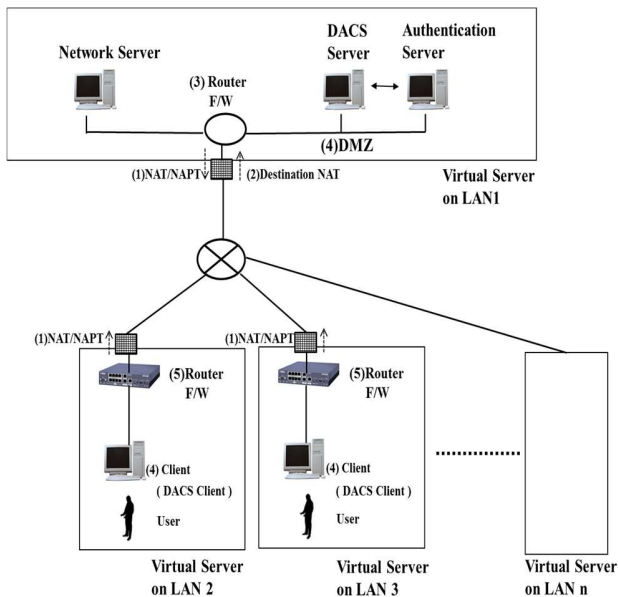

Figure 6. Basic System Configuration of wDACS system

First, as preconditions, because private IP addresses are assigned to all servers and clients existing in from LAN1 to LAN n, mechanisms of NAT/NAPT are necessary for the communication from each LAN to the outside. In this case, NAT/NAPT is located on the entrance of the LAN such as (1), and the private IP address is converted to the global IP address towards the direction of the arrow. Next, because the private IP addresses are set on the servers and clients in the LAN, other communications except those converted by Destination NAT cannot enter into the LAN. But, responses for the communications sent form the inside of the LAN can enter into the inside of the LAN because of the reverse conversion process by the NAT/NAPT. In addition, communications from the outside of the LAN1 to the inside are performed through the conversion of the destination IP address by Destination NAT. To be concrete, the global IP address at the same of the outside interface of the router is changed to the private IP address of each server. From here, system configuration of each LAN is described. First, the DACS Server and the authentication server are located on the DMZ on the LAN1 such as (4). On the entrance of the LAN1, NAT/NAPT and destination NAT exists such as (1) and (2). Because only the DACS Server and network

servers are set as the target destination, the authentication server cannot be accessed from the outside of the LAN1. In the LANs form LAN 2 to LAN n, clients managed by the wDACS system exist, and NAT/NAPT is located on the entrance of each LAN such as (1). Then, F/W such as (3) or (5) exists behind or with NAT/NAPT in all LANs

### 3.3 The Cloud Type Virtual PBNM for the Common Use Between Plural Organizations

In this section, after the concept and implementation of the proposed scheme were described, functional evaluation results are described.

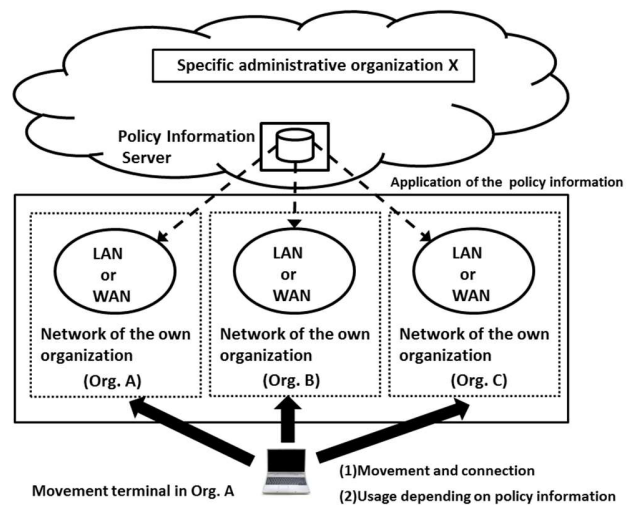

Figure 7. Cloud Type Virtual PBNM for the Common Use between Plural Organizations

In Figure 7 which is described in [16], the proposed concept is shown. Because the existing wDACS Scheme realized the PBNM control with the software called the DACS Server and the DACS client, other mechanism was not needed. By this point, application to the cloud environment was easy. The proposed scheme in this paper realizes the common usage by plural organizations by adding the following elements to realize the common usage by plural organizations: user identification of the plural organizations, management of the policy information of the plural organizations, application of the PKI for code communication in the Internet, Redundant configuration of the DACS Server (policy information server), load balancing configuration of the DACS Server, installation function of DACS Client by way of the Internet. In the past study [14], the DACS Client was operated on the windows operation system (Windows OS). It was because there were many cases that the Windows OS was used for as the OS of the client. However, the Linux operating system (Linux OS) had enough functions to be used as the client recently, too.

Therefore, to prove the possibility of the DACS Scheme on the Linux OS, the basic function of the DACS Client was implemented in this study. The basic functions of the DACS Server and DACS Client were implemented by JAVA language.

### 3.4 The Cloud Type Virtual PBNM for the specific domain

This scheme is to manage the plural networks group. In Figure 8, the content of it is explained. Specifically, as a logical range to manage organization A and organization B, network group 1 exists. Similarly, as a logical range to manage organization C and organization D, network group 2 exists. These individual network groups are existing methods listed in Figure 7. When plural network groups managed by this existing scheme exist, those plural network groups are targeted for management by this proposed method.

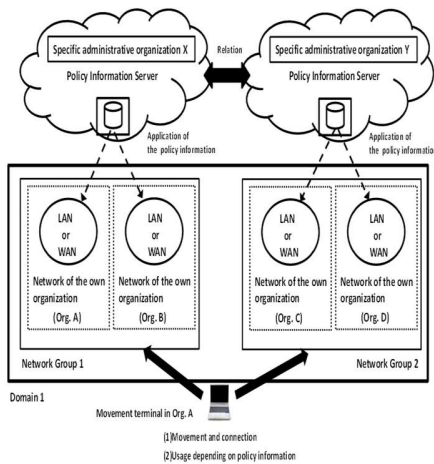

Figure 8. Cloud Type Virtual PBNM for the Specific Domain

For example, when user A belonging to org. A in network group1 uses the network which org. C belonging to network group2 which is a different network group holds, administrative organization Y for network group2 refers for policy information of user A for administrative organization X of network group1 and acquires it. After it, in the form that policy information registered with Network Group2 beforehand is collated with the policy information, the final policy information is decided. As a result, the policy information is applied to the client that user A uses in network group2, and the communication control on the client is performed. When a user moves plural network groups as well as the specific network group, it is thought that the PBNM scheme to keep a certain constant management state is realized.

The proposed user authentication system also has a distributed system form. For example, when user A belonging to org. A in network group1 accesses the network of the network group1, the user authentication process is generated for the user authentication server for the network group1. On the other hand, when user A belonging to org. A in network group1 accesses the network of the network group 2, the user authentication process is generated for the user authentication server for the network group1 as Figure.9.

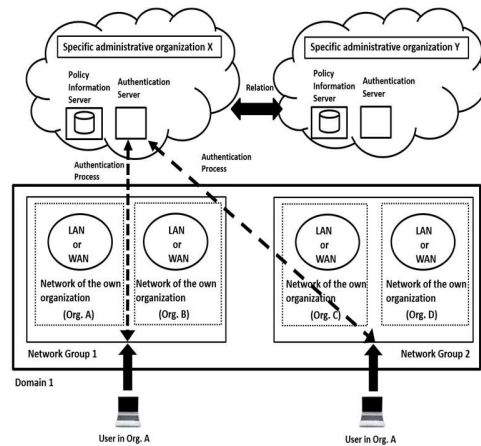

Figure 9. Concept of the proposed user authentication method

## 4. Basic system design of the Proposed PBNM

### 4.1 Concept of The Proposed PBNM

In this section, concept of cyber physical type of Internet PBNM is described. To extend to the proposed scheme described in the previous chapters, operation automation of the proposed scheme is required. Since the Internet system is an autonomous decentralized network, network operation management is performed for each organizational unit. Therefore, it is also necessary to make the proposed scheme an operation management scheme that can support autonomous decentralized type. In some cases, it may be possible to collectively manage the operation of a certain range of networks. Therefore, it is necessary to automate operation management as much as possible. Therefore, it is necessary to adopt a scheme that supports cyber-physical systems that utilize AI, big data, and IOT as shown in Figure 10. The control range in this figure is assumed to correspond to the range in Figure.7.

In this figure, the server group on the cloud space is arranged in the upper half, and the terminal group is arranged in the lower half. What is done by this server group is as follows. Big data collected from each terminal is statistically processed, and AI refers to the statistical information to make some judgment. Then, based on the

judgment result, the network control information used in the proposed PBNM scheme is automatically generated and transmitted to each terminal. Communication control is performed on each terminal that receives the control information.

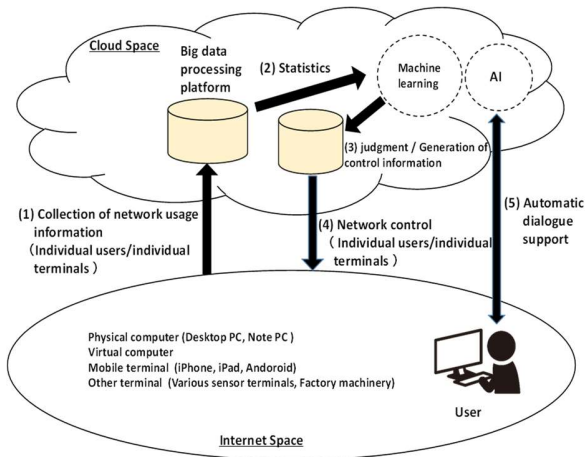

Figure 10. Image of cyber physical Type of Internet PBNM

Then, the various terminals in the lower half include physical terminals such as desktop PC and note-type PC, and other terminals such as virtual terminals, mobile terminals, and sensor terminals. Information about the usage status of these terminals and outgoing communications is sent to the big data processing platform on the cloud for processing. Then, after going through the above series of processing processes, network control information is transmitted, and communication control is performed by receiving it.

In addition, it should be equipped with a function for inquiries from users regarding operation management by AI. Even in the current operation management by network administrator as a human, the task of responding to questions from users is extremely important and difficult. If the proposed scheme is to be extended to the entire Internet system, the workload will be extremely large. Therefore, this work also needs an alternative function by AI.

### 5. Fundamental technologies for data processing

Essential technologies for data processing of the proposed system, many processing techniques are combined for their developments. As the first step, we have developed the basic technologies for the data processing.

### 4.2 Generation of Orthogonal Subspaces

To handle many kinds of data on the dataspace, the data are expected to be processed effectively for the combination of different data, exact tracking of data, correct classification of data, incremental data processing and learning the combined data. To satisfy all these requirements, several fundamental technologies are expected to combine them, effectively.

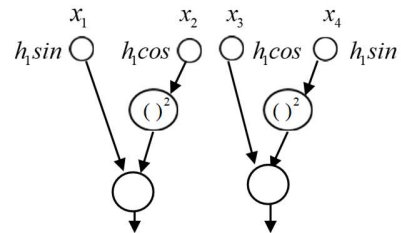

Fig.11. Basic unit of orthogonal wavelet basis

We develop the fundamental networks with orthogonal basis in Fig.11, which is a bio-inspired neural network[17]. By applying the

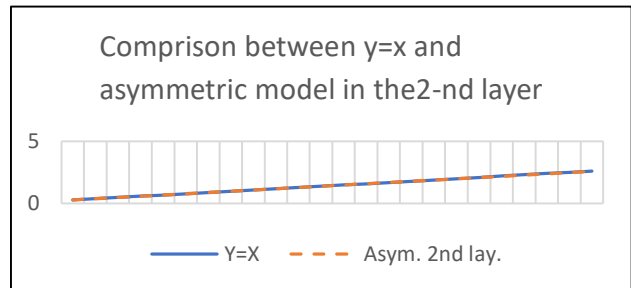

Fig.12. Tracking data in the neural networks with orthogonal subspace

network in Fig.11, the tracking data of  $y=x$  is experimented. The tracking using the network is well shown in Fig.12, while the conventional neural network is insufficient for the exact tracking as shown in Fig.13.

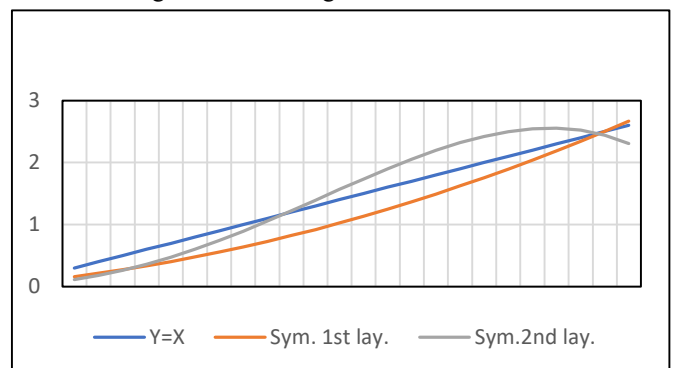

Fig.13. Tracking data movement in the conventional network

## 6. Conclusion

In this paper, considering affinity with the Internet system, concept of the proposed PBNM scheme was described. By this scheme, multiple domains are managed autonomously. As near future study, methods such as user authentication and registration and distribution of policy information need to be considered in a form that matches the current Internet mechanism.

## Acknowledgement

This work was supported by the research grant by Support Center for Advanced Telecommunications Technology Research, Foundation (SCAT). We express our gratitude.

## References

- [1] V. CERF and E. KAHN, "A Protocol for Packet Network Interconnection," IEEE Trans. on Commn, vol.COM-22, May 1974, pp.637-648.
- [2] R. Yavatkar, D. Pendarakis and R. Guerin, "A Framework for Policy-based Admission Control," IETF RFC 2753, 2000.
- [3] B. Moore et al., "Policy Core Information Model -- Version 1 Specification," IETF RFC 3060, 2001.
- [4] B. Moore., "Policy Core Information Model (PCIM) Extensions," IETF 3460, 2003.
- [5] J. Strassner, B. Moore, R. Moats, E. Ellesson, "Policy Core Lightweight Directory Access Protocol (LDAP) Schema," IETF RFC 3703, 2004.
- [6] D. Durham et al., "The COPS (Common Open Policy Service) Protocol," IETF RFC 2748, 2000.
- [7] S. Herzog et al., "COPS usage for RSVP," IETF RFC 2749, 2000.
- [8] K. Chan et al., "COPS Usage for Policy Provisioning (COPS-PR)," IETF RFC 3084, 2001.
- [9] CIM Core Model V2.5 LDAP Mapping Specification, 2002.
- [10] M. Wahl, T. Howes, S.Kille, "Lightweight Directory Access Protocol (v3)," IETF RFC 2251, 1997.
- [11] CIM Schema: Version 2.30.0, 2011.
- [12] ETSI ES 282 003: Telecoms and Internet converged Services and protocols for Advanced Network (TISPAN); Resource and Admission Control Subsystem (RACS); Functional Architecture, June 2006.
- [13] ETSI ETSI ES 283 026: Telecommunications and Internet Converged Services and Protocols for Advanced Networking (TISPAN); Resource and Admission Control; Protocol for QoS reservation information exchange between the Service Policy Decision Function (SPDF) and the Access-Resource and Admission Control Function (A-RACF) in the Resource and Protocol specification, April 2006.
- [14] K. Odagiri, R. Yaegashi, M. Tadauchi, and N. Ishii, "Secure DACS Scheme," Journal of Network and Computer Applications," Elsevier, Vol.31, Issue 4, 2008, pp.851-861, November.
- [15] K. Odagiri, S. Shimizu, M. Takizawa and N. Ishii, "Theoretical Suggestion of Policy-Based Wide Area Network Management System (wDACS system part-I)," International Journal of Networked and Distributed Computing (IJNDC), Vol.1, No.4, November 2013, pp.260-269.
- [16] K. Odagiri, S. Shimizu, N. Ishii, M. Takizawa, "Suggestion of the Cloud Type Virtual Policy Based Network Management Scheme for the Common Use between Plural Organizations," Proc of Int. Conf. on International Conference on Network-Based Information Systems (NBIS-2015), pp.180-186, September, 2015
- [17] [17] N. Ishii, T. Deguchi, M. Kawaguchi, H. Sasaki, T. Matsuo, "Adaptive Orthogonal Characteristics of Bio-inspired Neural Networks", Intell. Data Eng. and Automated Learning (IDEAL2019), LNCS, 11871, Springer 2019, pp.47-59.

**Kazuya Odagiri** received the degree of B.S in 1998 from Waseda University. He is an Associate Professor in Sugiyama Jogakuen University now. In addition, he got his Ph.D. in Aichi Institute of Technology. He engages in a study of network management.

**Shyogo Shimizu** received the degree of B.S in 1996 from Osaka University and the degree of M.S in 1998 from Nara Institute of Science and Technology, Nara. He got his Ph.D. in Nara Institute of Science and Technology in March 2001. He is now Associate Professor in Gakushuin Women's College.

**Naohiro Ishii** received the B.E., M.E. and Dr. of Engineering degree from Tohoku University, Japan in 1963, 1965 and 1968, respectively. He was a professor in Department of Intelligence and Computer Science at Nagoya Institute of Technology. From 2003, he was a professor in Department of Information Science at Aichi Institute of Technology until 2019. He belongs to Advanced Institute of Industrial Technology now. His research interest includes computer engineering, artificial intelligence, and human interface.